

# EXECUTIVE

Pricelist 06/2025

REV.10 10-06

 MOVING

# index

---

6	ALIA C
14	ALIA C Visitor
18	ALIA Top
24	ALIA Top Visitor
28	AURELIA
38	AURELIA Visitor
42	VIVA
48	VIVA Visitor



**1. SCHIENALE:**

Monoscocca in tubo sagomato d'acciaio, Ø 25mm, finitura cromata (15µm) rete portante, imbottita con spugna e rivestita

**2. MECCANISMO:**

- Oscillante nero, comando elevazione a gas, regolazione tensione schienale, inclinazione 18°scocca in 5 posizioni con antishock
- Comando elevazione a gas, finitura nera
- Molla oscillante in alluminio cromato
- Dispositivo di ritorno automatico 90° altezza fissa

**3. GAS:**

- Regolabile in altezza, rotazione, finitura cromata, molleggio
- Regolabile in altezza, rotazione, finitura cromata

**4. BASE:**

- Base 5 razze in alluminio, Ø 710mm, finitura lucida
- Base 5 razze in ferro, Ø 710mm, finitura cromata (15µm)

**5. RUOTE:**

- Ruote Ø 65mm, gommate o autofrenanti e gommate, finitura nera.
- Ruote Ø 50mm, autofrenanti o autofrenanti e gommate, finitura cromata
- Ruote gommate forate Ø 65mm

**6. BRACCIOLI:**

Bracciolo fisso in tubo tondo d'acciaio, Ø 25mm, finitura cromata (15µm) o rivestito

TECHNICAL INFORMATION

**1. BACKREST:**

Shaped steel tube monocoque, Ø 25mm, chromed finish. (15µm), load bearing Mesh. Foam padded and upholstered

**2. MECHANISM:**

- Black, tilting, gas lift height adj., backrest tension adj. 18°grade with 5 locking position, and antishock
- Height adjustable, Black finish
- Aluminium chromed tilting spring
- Memory swivel 90°, not height-adjustable

**3. GAS LIFT:**

- Height adjustable, swivel, chromed finish, shock absorber springs
- Height adjustable, swivel, chromed finish

**4. BASE:**

- Polished aluminium 5 spoke base, Ø 710 mm
- Iron 5 spoke base, Ø 710 mm chromed finish (15µm)

**5. CASTORS:**

- Ø 65mm self-braking castors, or soft self-bracking. Black finish
- Ø 50 mm self-braking castors, or soft self-bracking. Chromed finish
- Soft castors Ø 65mm with holes

**6. ARMREST:**

Fixed armrest, round steel tube Ø 25mm, chromed finish (15µm), or upholstered

**1. DOSSIER:**

Monocoque en tube d'acier Ø 25mm, finition chromée (15µm). Résille autoportante rembourrée de mousse et tapissée

**2. MECANISME:**

- Basculant noir, réglage en hauteur, réglage de tension, inclinaison coque 18°en 5 positions avec système antichoc
- Réglable en hauteur, finition noir
- Ressort basculant en aluminium pol
- Retour automatique 90°, non réglable en hauteur

**3. VERIN A GAZ:**

- Réglable en hauteur, pivotant, finition chromé, amortisseur
- Réglable en hauteur, pivotant, finition chromé

**4. PIETEMENT:**

- Piètement 5 branches alu poli, Ø 710mm
- Piètement 5 branches en métal, Ø 710mm, finition chromé (15µm)

**5. ROULETTES:**

- Roulettes Ø 65mm, gommées ou autofreinantes et gommées, finition noir
- Roulettes Ø 50mm, autofreinantes ou autofreinantes et gommées, finition chromé
- Roulettes creuses Ø 65mm gommées

**6. ACCOUDOIR:**

Accoudoir fixe en tube rond d'acier, Ø 25mm, finition chromé (15µm) ou tapissé

**1. RÜCKENLEHNE:**

Geförmtes Stahlrohr Gestell, Ø 25mm, verchromt (15µm) tragendes Netz, mit Schwamm gepolstert und bezogen

**2. MECHANIK:**

- Schwarze Wippmechanik, Gaslift Höhenverstellung, Rückenlehne mit Spannungsregler, 18°Schaleneigung mit 5-stufige Einstellung mit Antishock
- Schwarze Sitzhöhenverstellung
- Aluminium polierte Feder Wippmechanik
- Rückstellautomatik 90°, nicht höhenverstellbar

**3. GASFEDER:**

- Sitzhöhenverstellung, drehbar, verchromt, mit Stoßdämpfende Feder
- Sitzhöhenverstellung, drehbar, verchromt

**4. GESTELL:**

- 5-Stern Alu poliertes Fußkreuz, Ø 710 mm
- 5-Stern Eisen Fußkreuz, Ø 710mm verchromt (15µm)

**5. ROLLEN:**

- Ø 65 mm gebremste, oder weiche gebremste Rollen, schwarze
- Ø 50 mm gebremste, oder weiche gebremste rollen, verchromt
- Weiche Designrollen Ø 65mm

**6. ARMLEHNEN**

Feste Armlehne aus Stahlrohr, Ø 25 mm, verchromt (15µm) oder Gepolstert

**1. RESPALDO:**

Tubo de acero con forma monocasco, Ø 25 mm, acabado cromado (15µm), malla, acolchada con espuma y cubierta

**2. MECANISMO:**

- Tilting negro, control de elevación de gas, ajuste de tensión posterior, cuerpo de inclinación de 18 ° en 5 posiciones con antishock
- Control de elevación de gas, acabado negro
- Muelle oscilante en aluminio cromado
- Retorno automático 90°, no ajustable en altura

**3. GAS:**

- Ajustable en altura, rotación, acabado cromado, resortes
- Ajustable en altura, rotación, acabado cromado

**4. BASE:**

- Base de 5 estrellas en aluminio, Ø 710 mm, acabado pulido
- Base de 5 estrellas en hierro, Ø 710 mm, acabado cromado (15µm)

**5. RUEDAS:**

- Ø 65mm, blandas o autofrenado y blandas, acabado negro
- Ruedas de Ø 50 mm, autofrenantes o autofrenantes y blandas, cromado
- Ruedas goma Ø 65 con huecos

**6. BRAZOS:**

brazos fijos en tubo de acero redondo, Ø 25 mm, acabado cromado (15µm) o tapizado

ON REQUEST

- Ruote Ø 65mm gommate autofrenanti (per versione base 5 razze alluminio)

- Soft self-braking castors Ø 65mm (alum. 5 spoke base only)

- Roulettes Ø 65mm gommées autofreinantes (pour version piet. 5 branches alu poli)

- Weiche gebremste Rollen Ø 65mm (nur für 5-Stern Alu-Fußkreuz)

- Ruedas goma Ø 65 autofreno (para base 5 rayos alum.)



ID 1111209602

# ALIAC



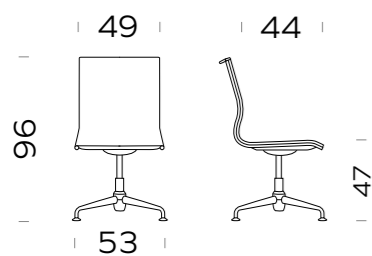

TRAVERSO A "C".  
"C" SHAPED BAR.  
TRAVERSE "C"  
TRAVERSE "C"  
TRANVERSA "C"



Mechanism: **Auto**

Dispositivo di ritorno automatico  
Memory Swivel  
Retour automatique  
Rückstellautomatik  
Retorno automático





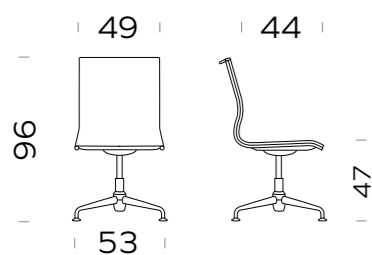

BASE BASE PIETEMET GESTELL BASE	RUOTA/PIEDINO CASTOR/FEET ROULETTES/PATINS ROLLEN/GLEITER RUEDAS/PIES	STRUTTURA STRUCTURE STRUCTURE STRUKTUR ESTRUCTURA	SCHIENALE BACKREST DOSSIER RÜCKENLEHNE RESPALDO	CODICE CODE CODE ARTIKEL CÓDIGO	KG	RETE MESH RÉSILLE NETZ MALLA
						L-M
 4 razze in ferro 4-spoke iron 4 branches en métal 4-Stern Eisen Fußkreuz a cruz en metal	 In tono Coordinated En teinte Je Farbton A juego	 Chromed	Medium	<b>AL0686</b>	13,20	870
			High	<b>AL0687</b>	13,50	880
		 RAL 9005	Medium	<b>AL0732</b>	13,20	810
			High	<b>AL0733</b>	13,50	820



Mechanism: **Tilting Spring**

Blocco oscillante, Regolazione altezza  
(Un-)locking device, Height adjustment  
Système de blocage-déblocage de l'oscillation, Réglage en hauteur  
Blockierung der Rückenlehnen / Höhenverstellung  
Sistema de bloqueo-desbloqueo del respaldo, Ajuste de altura



BASE BASE PIETEMET GESTELL BASE	RUOTA/PIEDINO CASTOR/FEET ROULETTES/PATINS ROLLEN/GLEITER RUEDAS/PIES	STRUTTURA STRUCTURE STRUCTURE STRUKTUR ESTRUCTURA	SCHIENALE BACKREST DOSSIER RÜCKENLEHNE RESPALDO	CODICE CODE CODE ARTIKEL CÓDIGO	KG	RETE MESH RÉSILLE NETZ MALLA
						L-M
 4 razze in ferro 4-spoke iron 4 branches en métal 4-Stern Eisen Fußkreuz a cruz en metal	 In tono Coordinated En teinte Je Farbton A juego	 Chromed	Medium	<b>AL0734</b>	12,30	865
			High	<b>AL0735</b>	12,64	875
		 RAL 9005	Medium	<b>AL0737</b>	12,30	805
			High	<b>AL0738</b>	12,64	815

\* DISPONIBILE ANCHE IN  
ALSO AVAILABLE  
ÉGALEMENT DISPONIBLE EN  
ERHÄLTICH AUCH IN  
TAMBIÉN DISPONIBLE EN

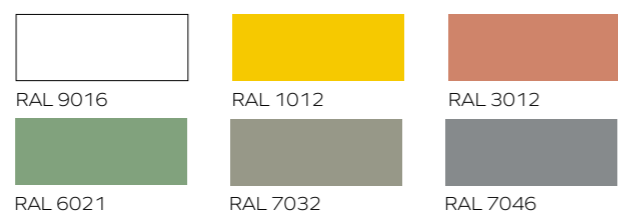

# ALIAC



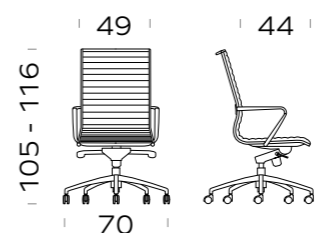
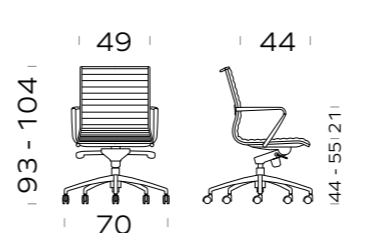









TRAVERSO A "C".  
"C" SHAPED BAR.  
TRAVERSE "C"  
TRAVERSE "C"  
TRANVERSA "C"



Mechanism: **SeatPlate**

Regolazione altezza  
Height adjustment  
Réglage en hauteur  
Höhenverstellung  
Ajuste de altura



BASE BASE PIETEMET GESTELL BASE	RUOTA/PIEDINO CASTOR/FEET ROULETTES/PATINS ROLLEN/GLEITER RUEDAS/PIES	STRUTTURA STRUCTURE STRUCTURE STRUKTUR ESTRUCTURA	SCHIENALE BACKREST DOSSIER RÜCKENLEHNE RESPALDO	CODICE CODE CODE ARTIKEL CÓDIGO	KG	RETE MESH RÉSILLE NETZ MALLA
						L-M
 5 razze in alluminio 5-spoke aluminium 5 branches alu 5-Stern Alu Fußkreuz estrella en aluminio	 d.65mm gommate soft d.65 mm d.65mm gommées weiche D.65 mm ruedas goma diam.65	 Chromed	Medium	<b>AL0440</b>	12,20	634
			High	<b>AL0012</b>	12,50	644
		 RAL 9005	Medium	<b>AL0739</b>	12,20	634
			High	<b>AL0740</b>	12,50	644
 5 razze in ferro 5-spoke iron 5 branches en métal 5-Stern es Eisen Fußkreuz estrella en metal	 d.50mm autofrenanti gommate soft self-braking d.50mm d.50 mm gommées autofrein. weiche gebremste D.50 mm ruedas goma diam.50 autofreno	 Chromed	Medium	<b>AL0446</b>	13,80	759
			High	<b>AL0378</b>	14,10	768
		 RAL 9005	Medium	<b>AL0741</b>	13,80	699
			High	<b>AL0742</b>	14,10	708
 4 razze in ferro 4-spoke iron 4 branches en métal 4-Stern Eisen Fußkreuz a cruz en metal	 In tono Coordinated En teinte Je Farbton A juego	 Chromed	Medium	<b>AL0449</b>	12,80	743
			High	<b>AL0334</b>	13,10	753
		 RAL 9005	Medium	<b>AL0743</b>	12,80	683
			High	<b>AL0744</b>	13,10	693

\* DISPONIBILE ANCHE IN  
ALSO AVAILABLE  
ÉGALEMENT DISPONIBLE EN  
ERHÄLTICH AUCH IN  
TAMBIÉN DISPONIBLE EN

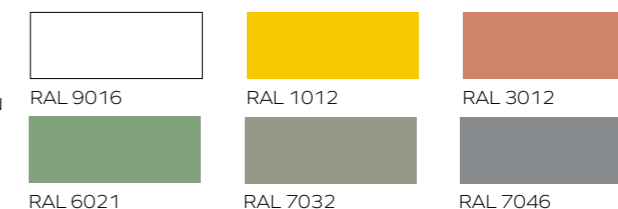

# ALIAC



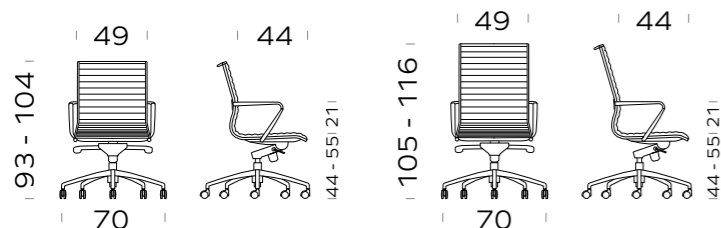











TRAVERSO A "C".  
"C" SHAPED BAR.  
TRAVERSE "C"  
TRAVERSE "C"  
TRANVERSA "C"



Mechanism: **Tilting BASIC**



Blocco oscillante-4 posizioni, Regolazione altezza/tensione  
(Un-)locking device-4 positions, Height/tension adjustment  
Système de blocage-débloccage de l'oscillation-4 positions, Réglage en hauteur/ d'intensité  
Blockierung der Rückenlehne /Spannungsregler / Höhenverstellung-4 Positionen  
Sistema de bloqueo-desbloqueo del respaldo-4 posiciones,  
Ajuste de altura/tensión

BASE BASE PIETEMENT GESTELL BASE	RUOTA/PIEDINO CASTOR/FEET ROULETTES/PATINS ROLLEN/GLEITER RUEDAS/PIES	STRUTTURA STRUCTURE STRUCTURE STRUKTUR ESTRUCTURA	SCHIENALE BACKREST DOSSIER RÜCKENLEHNE RESPALDO	CODICE CODE CODE ARTIKEL CÓDIGO	KG	RETE MESH RÉSILLE NETZ MALLA
						L-M
 5 razze in alluminio 5-spoke aluminium 5 branches alu 5 - Stern Alu Fußkreuz estrella en aluminio	 * d.65mm gommate soft d.65 mm d.65mm gommées weiche D.65 mm ruedas goma diam.65	 Chromed	Medium	<b>AL0782</b>	15,40	657
			High	<b>AL0783</b>	15,70	669
		 RAL 9005	Medium	<b>AL0784</b>	15,40	657
			High	<b>AL0785</b>	15,70	669
 5 razze in ferro 5-spoke iron 5 branches en métal 5 - Stern es Eisen Fußkreuz estrella en metal	 * d.50mm autofrenanti gommate soft self-braking d.50mm d.50 mm gommées autofrein. weiche gebremste D.50 mm ruedas goma diam.50 autofreno	 Chromed	Medium	<b>AL0786</b>	17,00	786
			High	<b>AL0787</b>	17,30	800
		 RAL 9005	Medium	<b>AL0788</b>	17,00	726
			High	<b>AL0789</b>	17,30	740
 5 razze poliammide 5-spoke polyamide 5 branches polyamide 5 - Stern Polyamid Fußkreuz estrella en polyamida	 * d.50mm autofrenanti gommate soft self-braking d.50mm d.50 mm gommées autofrein. weiche gebremste D.50 mm ruedas goma diam.50 autofreno	 RAL 9005	Medium	<b>AL0790</b>	14,70	595
			High	<b>AL0791</b>	15,00	607
 5 razze design poliammide 5-spoke polyamide design design 5 branches polyamide 5 - Stern Polyamid Design Fußkreuz design estrella en polyamida	 * d.50mm autofrenanti gommate soft self-braking d.50mm d.50 mm gommées autofrein. weiche gebremste D.50 mm ruedas goma diam.50 autofreno	 RAL 9005	Medium	<b>AL0792</b>	14,70	602
			High	<b>AL0793</b>	15,00	614

\* DISPONIBILE ANCHE IN  
ALSO AVAILABLE  
ÉGALEMENT DISPONIBLE EN  
ERHÄLTlich AUCH IN  
TAMBIÉN DISPONIBLE EN

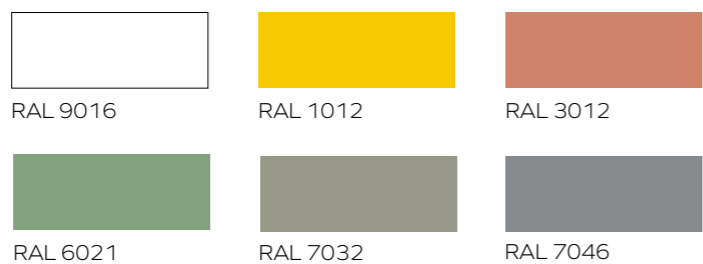

# ALIAC



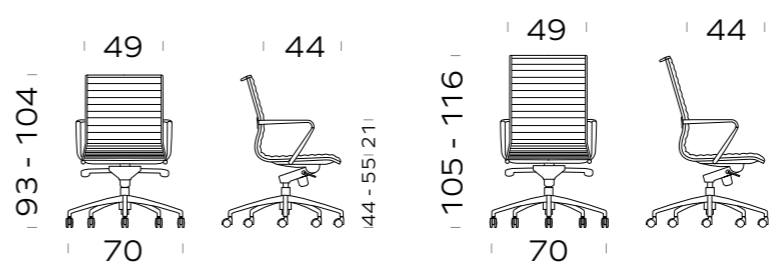





TRAVERSO A "C".  
"C" SHAPED BAR.  
TRAVERSE "C"  
TRAVERSE "C"  
TRANVERSA "C"



Mechanism: **Tilting ADVANCED PIVOT POINT**



Blocco oscillante-5 posizioni, Regolazione altezza/tensione  
(Un-)locking device-5 positions, Height/tension adjustment  
Système de blocage-débloccage de l'oscillation-5 positions, Réglage en hauteur/ d'intensité  
Blockierung der Rückenlehne /Spannungsregler / Höhenverstellung-5 Positionen  
Sistema de bloqueo-desbloqueo del respaldo-5 posiciones,  
Ajuste de altura/tensión

BASE BASE PIETEMENT GESTELL BASE	RUOTA/PIEDINO CASTOR/FEET ROULETTES/PATINS ROLLEN/GLEITER RUEDAS/PIES	STRUTTURA STRUCTURE STRUCTURE STRUKTUR ESTRUCTURA	SCHIENALE BACKREST DOSSIER RÜCKENLEHNE RESPALDO	CODICE CODE CODE ARTIKEL CÓDIGO	KG	RETE MESH RÉSILLE NETZ MALLA
						L-M
 5 razze in alluminio 5-spoke aluminium 5 branches alu 5 - Stern Alu Fußkreuz estrella en aluminio	 * d.65mm gommate soft d.65 mm d.65mm gommées weiche D.65 mm ruedas goma diam.65	 Chromed	Medium	<b>AL0431</b>	15,70	717
			High	<b>AL0003</b>	16,00	729
		 RAL 9005	Medium	<b>AL0745</b>	15,70	717
			High	<b>AL0746</b>	16,00	729
 5 razze in ferro 5-spoke iron 5 branches en métal 5 - Stern es Eisen Fußkreuz estrella en metal	 * d.50mm autofrenanti gommate soft self-braking d.50mm d.50 mm gommées autofrein. weiche gebremste D.50 mm ruedas goma diam.50 autofreno	 Chromed	Medium	<b>AL0435</b>	17,30	846
			High	<b>AL0009</b>	17,60	860
		 RAL 9005	Medium	<b>AL0747</b>	17,30	786
			High	<b>AL0748</b>	17,60	800

\* DISPONIBILE ANCHE IN  
ALSO AVAILABLE  
ÉGALEMENT DISPONIBLE EN  
ERHÄLTlich AUCH IN  
TAMBIÉN DISPONIBLE EN



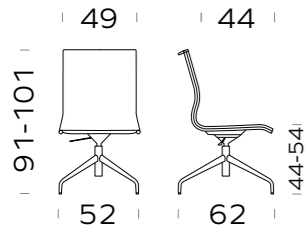



Mechanism: **Tilting Spring**

Blocco oscillante, Regolazione altezza  
(Un-)locking device, Height adjustment  
Système de blocage-déblocage de l'oscillation, Réglage en hauteur  
Blockierung der Rückenlehne / Höhenverstellung  
Sistema de bloqueo-desbloqueo del respaldo, Ajuste de altura



BASE BASE PIETEMENT GESTELL BASE	RUOTA/PIEDINO CASTOR/FEET ROULETTES/PATINS ROLLEN/GLEITER RUEDAS/PIES	STRUTTURA STRUCTURE STRUCTURE STRUKTUR ESTRUCTURA	SCHIENALE BACKREST DOSSIER RÜCKENLEHNE RESPALDO	CODICE CODE ARTIKEL CÓDIGO	KG	RETE MESH RÉSILLE NETZ MALLA
						L-M
 piramidale in ferro pyramid iron pyramid en métal pyramid aus Eisen piramidal en hierro	 neri con fletrini black with felts noirs avec feutres schwarze Filzgleiter negros con feltro	 RAL 9005	Medium	<b>AL0710</b>	14,30	633

\* DISPONIBILE ANCHE IN  
ALSO AVAILABLE  
ÉGALEMENT DISPONIBLE EN  
ERHÄLTICH AUCH IN  
TAMBIÉN DISPONIBLE EN



RAL 9016



RAL 6021



RAL 1012









RAL 7032











RAL 3012

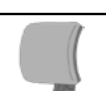

RAL 7046

OPZIONE OPTIONALS OPTIONS OPTIONEN OPCIONES	VARIANTE VARIANT VARIANTE VARIANTE VARIANTE	CODICE CODE ARTIKEL CÓDIGO	KG	PREZZO PRICE PRIX PREIS PRECIO	TESSUTI/FINITURE UPHOLSTERIES/FINISHING REVETEMENTS STOFFGRUPPE TAPICERÍAS				
					D	E	F	G	H
	Chromed	<b>XB005</b>	2,80	146					
	* 	<b>XB101</b>	2,80	121					
	Chromed	<b>XB008</b>	3,00		218	218	218	218	218
	* 	<b>XB100</b>	3,00		193	193	193	193	193
	Small Desk Pad 50x35 cm	<b>XA020</b>	2,30					130	
	Large Desk Pad 80x50 cm	<b>XA021</b>	5,30					246	
<b>SEAT</b> 		<b>XC005</b>	0,50		88	95	100	144	280

OPZIONE OPTIONALS OPTIONS OPTIONEN OPCIONES	CODICE CODE ARTIKEL CÓDIGO	KG	PREZZO PRICE PRIX PREIS PRECIO	TESSUTI/FINITURE UPHOLSTERIES/FINISHING REVETEMENTS STOFFGRUPPE TAPICERÍAS				
				D	E	F	G	H
<b>MEDIUM</b> 	<b>XC004</b>	2,00		387	397	404	507	811
<b>HIGH</b> 	<b>XC003</b>	2,00		455	463	472	573	918
<b>MEDIUM</b> 	<b>XC002</b>	1,00		277	288	295	320	520
<b>HIGH</b> 	<b>XC001</b>	1,00		288	298	311	343	543
<b>MEDIUM</b> 	<b>XC033</b>	0,50		163	173	180	205	405
<b>HIGH</b> 	<b>XC034</b>	0,50		176	186	199	231	431
	<b>XT001</b>	0,80		173	173	173	173	173
	<b>XR006</b>	0,30	35					

\* DISPONIBILE ANCHE CON  
ALSO AVAIAABLE WITH  
ÉGALEMENT DISPONIBLE AVEC  
ERHÄLTICH AUCH MIT  
TAMBIÉN DISPONIBLE CON



d.65 mm gommate forate  
self-braking d.65 mm perforated  
d.65 mm autofreinante perforé  
gebremste Rollen Design D.65 mm  
diam.65 autofreno perforado

**+100€**

\* DISPONIBILE ANCHE IN  
ALSO AVAILABLE  
ÉGALEMENT DISPONIBLE EN  
ERHÄLTICH AUCH IN  
TAMBIÉN DISPONIBLE EN



RAL 9016



RAL 6021



RAL 1012



RAL 7032



RAL 3012



RAL 7046

# ALIA C Visitor

design: Ambostudio



## TECHNICAL INFORMATION

### 1. SCHIENALE:

Monoscocca in tubo sagomato d'acciaio, Ø 25mm, finitura cromata (15µm) rete portante a vista

### 2. BASE:

- Base a slitta in tubo d'acciaio Ø 25mm, finitura cromata (15µm)
- Trave in tubo rettangolare d'acciaio, 60x30mm, finitura cromata (15µm) con gambe in tubo tondo d'acciaio, Ø30mm, finitura cromata

### 3. PIEDINI:

- Tappi antiribaltamento in poliammide, finitura cromata (15µm)
- Piedini cromati

### 1. BACKREST :

Shaped steel tube monocoque, Ø 25mm, chromed finish. (15µm). Visible load bearing Mesh

### 2. BASE:

- Cantilever base, Ø 25 mm steel tube, chromed finish (15µm)
- Rect. Steel tube bar 60x30mm, chromed finish (15µm) with steel tube legs Ø30mm, chromed finish

### 3. FEET:

- Polyamide anti overturning plugs, chromed (15µm)
- Chromed Glides

### 1. DOSSIER:

Monocoque en tube d'acier Ø 25mm, finition chromée (15µm). Résille autoportante à vue

### 2. PIÈTEMENT:

- Piètement luge en tube d'acier Ø 25mm, finition chromé (15µm)
- Poutre en tube d'acier rectangulaire, 60x30mm, finition chromé (15µm) avec pieds en tube d'acier, Ø30mm, finition chromé

### 3. PATINS:

- Tampons anti renversement en polyamide, finition chromé (15µm)
- Patins finition chromée

### 1. RÜCKENLEHNE :

Geformtes Stahlrohr Gestell, Ø 25mm, verchromt (15µm) sichtbares tragendes Netz

### 2. GESTELL :

- Freischwinger Gestell, Ø 25mm Stahlrohr verchromt (15µm)
- Rechteckige Stahlrohrbalken, 60x30 mm, verchromt (15µm) mit Stahlrohrbeine, Ø 30 mm, verchromt

### 3. GLEITER :

- Anti Unkippleiter aus Polyamid, verchromt (15µm)
- Gleiter, verchromt

### 1. RESPALDO:

Monoscafo en tubo de acero con forma, Ø 25 mm, Malla, con acabado cromado (15µm)

### 2. BASE:

- Base de trineo en tubo de acero de Ø 25 mm, acabado cromado (15µm)
- Viga en tubo de acero rectangular, 60x30 mm, acabado cromado (15µm) con patas en tubo de acero redondo, Ø30 mm, acabado cromado

### 3. PIES:

- Tapas antivuelco de poliamida, acabado cromado (15µm)
- Piernas cromadas







ID 1111209614

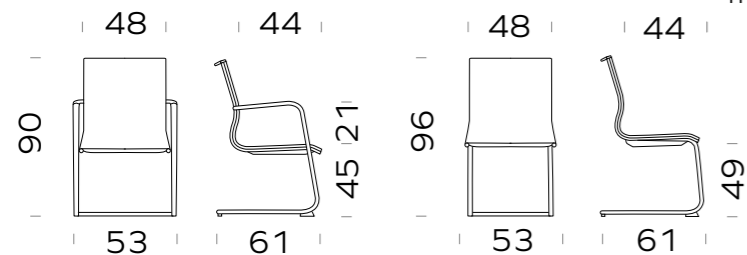



# ALIAC

TRAVERSO A "C", SCHIENALE MEDIO  
 "C" SHAPED BAR, MEDIUM BACKREST  
 TRAVERSE "C", MOYEN DOSSIER  
 TRAVERSE "C", MITTLERE RÜCKENLEHNE  
 TRANVERSA "C", MEDIO RESPALDO



## VISITOR

BASE BASE PIETEMET GESTELL BASE	RUOTA/PIEDINO CASTOR/FEET ROULETTES/PATINS ROLLEN/GLEITER RUEDAS/PIES	STRUTTURA STRUCTURE STRUCTURE STRUKTUR ESTRUCTURA	VARIANTE VARIANT VARIANTE VARIANTE VARIANTE	CODICE CODE CODE ARTIKEL CÓDIGO	KG	RETE MESH RÉSILLE NETZ MALLA
						L-M
 slitta cantilever luge Freischwinger patin	 feltrini felts feutres Filzgleiter fieltro	 Chromed	con braccioli with arms avec accoudories mit Armlehnen con brazos	<b>AL0474</b>	12,60	602
			senza braccioli without arms sans accoudories ohne Armlehnen sin brazos	<b>AL0719</b>	10,70	552
		 RAL 9005 *	con braccioli with arms avec accoudories mit Armlehnen con brazos	<b>AL0695</b>	12,60	536
			senza braccioli without arms sans accoudories ohne Armlehnen sin brazos	<b>AL0711</b>	10,70	498

OPZIONE OPTIONALS OPTIONS OPTIONEN OPCIONES	CODICE CODE CODE ARTIKEL CÓDIGO	KG	TESSUTI/FINITURE UPHOLSTERIES/FINISHING REVETEMENTS STOFFGRUPPE TAPICERIAS				
			D	E	F	G	H
	<b>XH001</b>	0,20	58	58	58	58	58
<b>SEAT</b> 	<b>XC005</b>	0,50	88	95	100	144	280
<b>MEDIUM</b> 	<b>XC004</b>	2,00	387	397	404	507	811
<b>MEDIUM</b> 	<b>XC002</b>	1,00	277	288	295	320	520
<b>MEDIUM</b> 	<b>XC033</b>	0,50	163	173	180	205	405

\* DISPONIBILE ANCHE IN  
 ALSO AVAILABLE  
 ÉGALEMENT DISPONIBLE EN  
 ERHÄLTLICH AUCH IN  
 TAMBIÉN DISPONIBLE EN

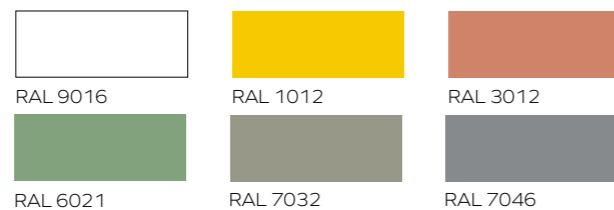

 D.MOVING



# ALIA Top

INTERAMENTE TAPPEZZATA, DOPPIO TRAVERSO A "C"  
 FULLY UPHOLSTERED, DOUBLE "C" SHAPED BAR  
 ENTIÈREMENT TAPISSEÉ, DOUBLE TRAVERSE "C"  
 AUSGEPOLSTERT, DOPPEL TRAVERSE "C"  
 COMPLETAMENTE TAPIZADA, DOBLE TRANVERSA "C"

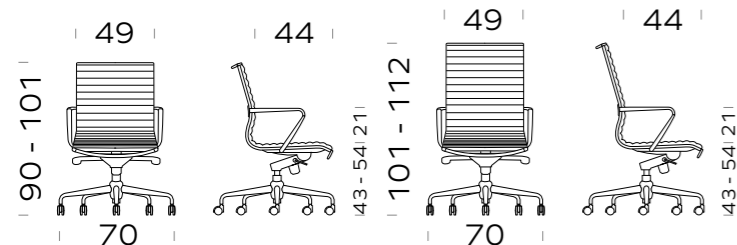

Mechanism: **SeatPlate**↑↓



Regolazione altezza  
 Height adjustment  
 Réglage en hauteur  
 Höhenverstellung  
 Ajuste de altura

BASE BASE PIETEMENT GESTELL BASE	RUOTA/PIEDINO CASTOR/FEET ROULETTES/PATINS ROLLEN/GLEITER RUEDAS/PIES	STRUTTURA STRUCTURE STRUCTURE STRUKTUR ESTRUCTURA	SCHIENALE BACKREST DOSSIER RÜCKENLEHNE RESPALDO	CODICE CODE ARTIKEL CÓDIGO	KG	TESSUTI/FINITURE UPHOLSTERIES/FINISHING REVETEMENTS STOFFGRUPPE TAPICERÍAS		
						F	G	H
<p>5 razze in alluminio                      5-spoke aluminium                      5 branches alu                      5 - Stern Alu Fußkreuz                      estrella en aluminio</p>	<p>d.65 gommata                      soft d.65 mm                      d.65mm gommées                      weiche D.65 mm                      ruedas goma diam.65</p>	<p>Chromed</p>	Medium	<b>AL0530</b>	13,20	1275	1527	1752
			High	<b>AL0304</b>	13,50	1294	1547	1770
		<p>RAL 9005</p>	Medium	<b>AL0750</b>	13,20	1275	1527	1752
			High	<b>AL0751</b>	13,50	1294	1547	1770
<p>5 razze in ferro                      5-spoke iron                      5 branches en métal                      5-Stern es Eisen Fußkreuz                      estrella en metal</p>	<p>d.50mm autofrenanti gommata                      soft self-braking d.50mm                      d.50 mm gommées autofrein.                      weiche gebremste D.50 mm                      ruedas goma diam.50 autofreno</p>	<p>Chromed</p>	Medium	<b>AL0534</b>	14,80	1394	1647	1870
			High	<b>AL0219</b>	15,10	1415	1667	1891
		<p>RAL 9005</p>	Medium	<b>AL0752</b>	14,80	1324	1577	1800
			High	<b>AL0753</b>	15,10	1345	1597	1821

\* DISPONIBILE ANCHE IN  
 ALSO AVAILABLE  
 ÉGALEMENT DISPONIBLE EN  
 ERHÄLTLICH AUCH IN  
 TAMBIÉN DISPONIBLE EN



RAL 9016



RAL 1012



RAL 3012



RAL 6021



RAL 7032



RAL 7046

# ALIA Top

INTERAMENTE TAPPEZZATA, DOPPIO TRAVERSO A "C"  
 FULLY UPHOLSTERED, DOUBLE "C" SHAPED BAR  
 ENTIÈREMENT TAPISSEÉ, DOUBLE TRAVERSE "C"  
 AUSGEPOLSTERT, DOPPEL TRAVERSE "C"  
 COMPLETAMENTE TAPIZADA, DOBLE TRANVERSA "C"

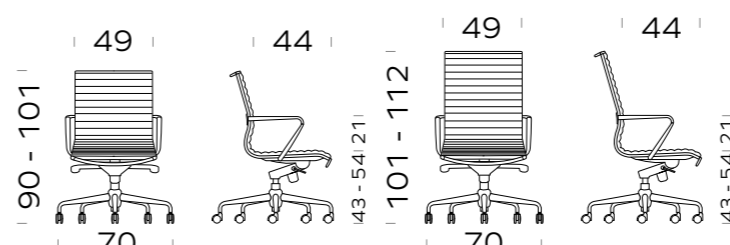

Mechanism: **Tilting**  
**BASIC**



Blocco oscillante-4 posizioni, Regolazione altezza/tensione  
 (Un-)locking device-4 positions, Height/tension adjustment  
 Système de blocage-déblocage de l'oscillation-4 positions, Réglage en hauteur/ d'intensité  
 Blockierung der Rückenlehne /Spannungsregler / Höhenverstellung-4 Positionen  
 Sistema de bloqueo-desbloqueo del respaldo-4 posiciones, Ajuste de altura/tensión

BASE BASE PIETEMENT GESTELL BASE	RUOTA/PIEDINO CASTOR/FEET ROULETTES/PATINS ROLLEN/GLEITER RUEDAS/PIES	STRUTTURA STRUCTURE STRUCTURE STRUKTUR ESTRUCTURA	SCHIENALE BACKREST DOSSIER RÜCKENLEHNE RESPALDO	CODICE CODE ARTIKEL CÓDIGO	KG	TESSUTI/FINITURE UPHOLSTERIES/FINISHING REVETEMENTS STOFFGRUPPE TAPICERÍAS		
						F	G	H
<p>5 razze in alluminio                      5-spoke aluminium                      5 branches alu                      5 - Stern Alu Fußkreuz                      estrella en aluminio</p>	<p>d.65mm gommata                      soft d.65 mm                      d.65mm gommées                      weiche D.65 mm                      ruedas goma diam.65</p>	<p>Chromed</p>	Medium	<b>AL0794</b>	16,40	1272	1524	1748
			High	<b>AL0795</b>	16,70	1293	1543	1768
		<p>RAL 9005</p>	Medium	<b>AL0796</b>	16,40	1272	1524	1748
			High	<b>AL0797</b>	16,70	1293	1543	1768
<p>5 razze in ferro                      5-spoke iron                      5 branches en métal                      5-Stern es Eisen Fußkreuz                      estrella en metal</p>	<p>d.50mm autofrenanti gommata                      soft self-braking d.50mm                      d.50 mm gommées autofrein.                      weiche gebremste D.50 mm                      ruedas goma diam.50 autofreno</p>	<p>Chromed</p>	Medium	<b>AL0798</b>	18,00	1391	1644	1867
			High	<b>AL0799</b>	18,30	1412	1664	1888
		<p>RAL 9005</p>	Medium	<b>AL0800</b>	18,00	1321	1574	1797
			High	<b>AL0801</b>	18,30	1342	1594	1818
<p>5 razze poliammide                      5-spoke polyamide                      5 branches polyamide                      5 - Stern Polyamid Fußkreuz                      estrella en poliamida</p>	<p>d.50mm autofrenanti gommata                      soft self-braking d.50mm                      d.50 mm gommées autofrein.                      weiche gebremste D.50 mm                      ruedas goma diam.50 autofreno</p>	<p>RAL 9005</p>	Medium	<b>AL0802</b>	15,70	1210	1462	1686
			High	<b>AL0803</b>	16,00	1231	1481	1706
<p>5 razze design poliammide                      5-spoke polyamide design                      design 5 branches polyamide                      5 - Stern Polyamid Design Fußkreuz                      design estrella en poliamida</p>	<p>d.50mm autofrenanti gommata                      soft self-braking d.50mm                      d.50 mm gommées autofrein.                      weiche gebremste D.50 mm                      ruedas goma diam.50 autofreno</p>	<p>RAL 9005</p>	Medium	<b>AL0804</b>	15,70	1217	1469	1693
			High	<b>AL0805</b>	16,00	1238	1488	1713

\* DISPONIBILE ANCHE IN  
 ALSO AVAILABLE  
 ÉGALEMENT DISPONIBLE EN  
 ERHÄLTLICH AUCH IN  
 TAMBIÉN DISPONIBLE EN

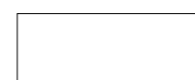

RAL 9016



RAL 1012



RAL 3012



RAL 6021



RAL 7032



RAL 7046

# ALIA Top

INTERAMENTE TAPPEZZATA, DOPPIO TRAVERSO A "C"  
 FULLY UPHOLSTERED, DOUBLE "C" SHAPED BAR  
 ENTIÈREMENT TAPISSEÉ, DOUBLE TRAVERSE "C"  
 AUSGEPOLSTERT, DOPPEL TRAVERSE "C"  
 COMPLETAMENTE TAPIZADA, DOBLE TRANVERSA "C"

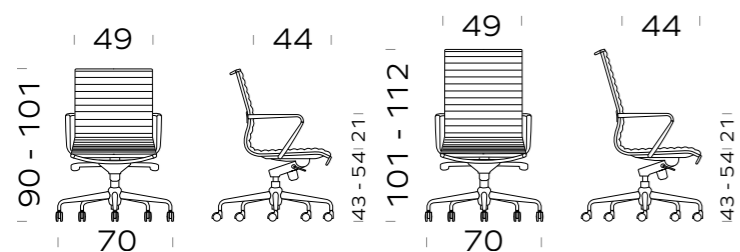

Mechanism: **Tilting**  
**ADVANCED PIVOT POINT**



Blocco oscillante-5 posizioni, Regolazione altezza/tensione  
 (Un-)locking device-5 positions, Height/tension adjustment  
 Système de blocage-débloccage de l'oscillation-5 positions, Réglage en hauteur/ d'intensité  
 Blockierung der Rückenlehne /Spannungsregler / Höhenverstellung-5 Positionen  
 Sistema de bloqueo-desbloqueo del respaldo-5 posiciones, Ajuste de altura/tensión

BASE BASE PIETEMENT GESTELL BASE	RUOTA/PIEDINO CASTOR/FEET ROULETTES/PATINS ROLLEN/GLEITER RUEDAS/PIES	STRUTTURA STRUCTURE STRUCTURE STRUKTUR ESTRUCTURA	SCHIENALE BACKREST DOSSIER RÜCKENLEHNE RESPALDO	CODICE CODE CODE ARTIKEL CÓDIGO	KG	TESSUTI/FINITURE UPHOLSTERIES/FINISHING REVETEMENTS STOFFGRUPPE TAPICERIAS		
						F	G	H
<p>5 razze in alluminio 5-spoke aluminium 5 branches alu 5-Stern Alu Fußkreuz estrella en aluminio</p>	<p>d.65 gomme soft d.65 mm d.65mm gommées weiche D.65 mm ruedas goma diam.65</p>	<p>Chromed</p>	Medium	<b>AL0523</b>	16,70	1332	1584	1808
			High	<b>AL0212</b>	17,00	1353	1603	1828
		<p>RAL 9005</p>	Medium	<b>AL0754</b>	16,70	1332	1584	1808
			High	<b>AL0755</b>	17,00	1353	1603	1828
<p>5 razze in ferro 5-spoke iron 5 branches en métal 5-Stern es Eisen Fußkreuz estrella en metal</p>	<p>d.50mm autofrenanti gomme soft self-braking d.50mm d.50 mm gommées autofrein. weiche gebremste D.50 mm ruedas goma diam.50 autofreno</p>	<p>Chromed</p>	Medium	<b>AL0527</b>	18,30	1451	1704	1927
			High	<b>AL0216</b>	18,60	1472	1724	1948
		<p>RAL 9005</p>	Medium	<b>AL0756</b>	18,30	1381	1634	1857
			High	<b>AL0757</b>	18,60	1402	1654	1878

\* DISPONIBILE ANCHE IN  
 ALSO AVAILABLE  
 ÉGALEMENT DISPONIBLE EN  
 ERHÄLTlich AUCH IN  
 TAMBIÉN DISPONIBLE EN



RAL 9016



RAL 1012



RAL 3012



RAL 6021



RAL 7032



RAL 7046

# ALIA Top

## OPTIONALS

OPZIONE OPTIONALS OPTIONES OPCIONES	VARIANTE VARIANT VARIANTE VARIANTE VARIANTE	CODICE CODE CODE ARTIKEL CÓDIGO	KG	PREZZO PRICE PRIX PREIS PRECIO	TESSUTI/FINITURE UPHOLSTERIES/FINISHING REVETEMENTS STOFFGRUPPE TAPICERIAS				
					D	E	F	G	H
	Chromed	<b>XB005</b>	2,80	146					
	*  RAL 9005	<b>XB101</b>	2,80	121					
	Chromed	<b>XB008</b>	3,00		218	218	218	218	218
	*  RAL 9005	<b>XB100</b>	3,00		193	193	193	193	193
	Small Desk Pad 50x35 cm	<b>XA020</b>	2,30					130	
	Large Desk Pad 80x50 cm	<b>XA021</b>	5,30						246

\* DISPONIBILE ANCHE CON  
 ALSO AVAILABLE WITH  
 ÉGALEMENT DISPONIBLE AVEC  
 ERHÄLTlich AUCH MIT  
 TAMBIÉN DISPONIBLE CON

d.65 mm gomme forate  
 self-braking d.65 mm perforated  
 d.65 mm autofreinante perforé  
 gebremste Rollen Design D.65 mm  
 diam.65 autofreno perforado

**+100€**

\* DISPONIBILE ANCHE IN  
 ALSO AVAILABLE  
 ÉGALEMENT DISPONIBLE EN  
 ERHÄLTlich AUCH IN  
 TAMBIÉN DISPONIBLE EN



RAL 9016



RAL 1012



RAL 3012



RAL 6021



RAL 7032



RAL 7046

# ALIA Top Visitor

design: Ambostudio



## TECHNICAL INFORMATION

### 1. SCHIENALE:

Monoscocca in tubo sagomato d'acciaio, Ø 25mm, finitura cromata (15µm), rete portante, imbottita con spugna e rivestita

### 2. BASE:

Base a slitta in tubo d'acciaio Ø 25mm, finitura cromata (15µm) con braccioli integrati

### 3. PIEDINI:

Tappi antiribaltamento in poliammide, finitura cromata (15µm)

### 1. BACKREST :

Shaped steel tube monocoque, Ø 25mm, chromed finish (15µm) Load bearing Mesh. Foam padded and upholstered

### 2. BASE:

Cantilever base, Ø 25 mm steel tube, chromed finish (15µm) with arms

### 3. FEET:

Polyamide anti overturning plugs, chromed (15µm)

### 1. DOSSIER:

Monocoque en tube d'acier Ø 25mm, finition chromée (15µm). Résille autoportante rembourrée de mousse et tapissée

### 2. PIÈTEMENT:

Piètement luge en tube d'acier Ø 25mm, finition chromé (15µm) avec acc.

### 3. PATINS:

Tampons anti renversement en polyamide, finition chromé (15µm)

### 1. RÜCKENLEHNE :

Geformtes Stahlrohr Gestell, Ø 25mm, verchromt (15µm) tragendes Netz, mit Schwamm gepolstert und bezogen

### 2. GESTELL :

Freischwinger Gestell, Ø 25mm Stahlrohr verchromt (15µm) mit Arm

### 3. GLEITER :

Anti Unkippleiter aus Polyamid, verchromt (15µm)

### 1. RESPALDO:

Tubo de acero con forma de monoscafo, Ø 25 mm, acabado cromado (15µm), malla d, acolchado con espuma y tapizado

### 2. BASE:

Base de trineo en tubo de acero de Ø 25 mm, acabado cromado (15µm) y brazos

### 3. PIES:

Tapas antivuelco de poliamida, acabado cromado (15µm)





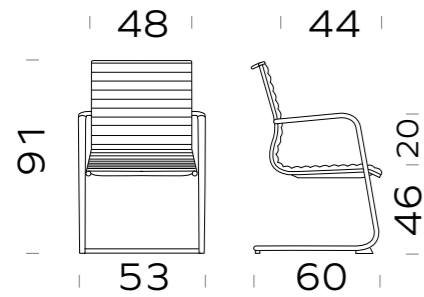

ID 1111209614

# ALIA Top

INTERAMENTE TAPPEZZATA, DOPPIO TRAVERSO, SCHIENALE MEDIO  
 FULLY UPHOLSTERED, DOUBLE BAR, MEDIUM BACKREST  
 ENTIÈREMENT TAPISSEÉ, DOUBLE TRAVERSE, MOYEN DOSSIER  
 AUSGEPOLSTERT, DOPPEL TRAVERSE, MITTLERE RÜCKENLEHNE  
 COMPLETAMENTE TAPIZADA, DOBLE TRANVERSA, MEDIO RESPLADO



## VISITOR

BASE BASE PIEYEMENT GESTELL BASE	RUOTA/PIEDINO CASTOR/FEET ROULETTES/PATINS ROLLEN/GLEITER RUEDAS/PIES	STRUTTURA STRUCTURE STRUCTURE STRUKTUR ESTRUCTURA	CODICE CODE CODE ARTIKEL CÓDIGO	KG	TESSUTI/FINITURE UPHOLSTERIES/FINISHING REVETEMENTS STOFFGRUPPE TAPICERÍAS		
					F	G	H
 slitta con braccioli cantilever with arms luge avec accoudoirs Freischwinger Gestell mit Armlehnen patin con brazos	 feltrini felts feutres Filzgleiter fieltro	 Chromed	<b>AL0547</b>	13,60	998	1102	1303
		 RAL 9005 *	<b>AL0705</b>	13,60	922	1026	1227

OPZIONE OPTIONALS OPTIONS OPTIONEN OPCIONES	CODICE CODE CODE ARTIKEL CÓDIGO	KG	TESSUTI/FINITURE UPHOLSTERIES/FINISHING REVETEMENTS STOFFGRUPPE TAPICERÍAS				
			D	E	F	G	H
	<b>XH001</b>	0,20	58	58	58	58	58

\* DISPONIBILE ANCHE IN  
 ALSO AVAILABLE  
 ÉGALEMENT DISPONIBLE EN  
 ERHÄLTlich AUCh IN  
 TAMBIÉN DISPONIBLE EN



RAL 9016



RAL 1012



RAL 3012



RAL 6021



RAL 7032



RAL 7046

 MOVING

# AURELIA

idea: *Pietro Lovato*



## 1. SCHIENALE E SEDILE:

Monoscocca in spugna schiumata a freddo con struttura portante in tubo tondo d'acciaio, Ø 20mm, rivestita

## 2. MECCANISMO:

- Oscillante nero, comando elevazione a gas, regolazione tensione schienale
- Comando elevazione a gas, finitura nera

## 3. GAS:

Regolabile in altezza, rotazione, finitura cromata

## 4. BASE:

5 razze in alluminio, Ø 710mm, finitura lucida.

## 5. RUOTE:

Ø 50mm, autofrenanti o autofrenanti e gommate, finitura nera

## 6. BRACCIOLO:

Bracciolo fisso in tondo d'acciaio, Ø 12mm, finitura cromata (15µm) con inserto in poliuretano morbido o rivestito

## 1. BACKREST AND SEAT :

Cold injected foam padding monocoque, Ø 20mm steel tube structure, upholstery

## 2. MECHANISM:

- Black tilting, gas lift height adj. Backrest tension adjustment.
- Height adjustable, Black finish

## 3. GAS LIFT:

Height adjustable, swivel, chromed finish

## 4. BASE:

Polished aluminium 5 spoke base, Ø 710 mm

## 5. CASTORS:

Ø 50 mm self-braking castors, or soft self-bracking. Black or Chromed finish

## 6. ARMREST:

Steel round bar fixed armrest, Ø 12mm, chromed finish (15µm) soft polyurethane insert or upholstered

## 1. DOSSIER ET ASSISE:

Monocoque en mousse moulée à froids avec châssis en tube d'acier rond, Ø 20mm, tapissée

## 2. MECANISME:

- Basculant noir, réglage en hauteur, réglage de tension
- Réglable en hauteur, finition noir

## 3. VERIN A GAZ:

Réglable en hauteur, pivotant, finition chromé

## 4. PIETEMENT:

Piètement 5 branches alu poli, Ø 710mm

## 5. ROULETTES:

Roulettes Ø 50mm, autofreinantes ou autofreinantes et gommées, finition noir

## 6. ACCOUDOIR:

Accoudoir fixe en tige d'acier, Ø 12mm, finition chromé (15µm) avec manchette en polyuréthane souple ou tapissé

## 1. RÜCKENLEHNE, SITZ :

Stahlrohrschale, Ø 20mm, ausgepolstert mit kaltgeschäumtem Polyurethan und Bezug

## 2. MECHANIK :

- Schwarze Wippmechanik, Gaslift Höhenverstellung, Rückenlehne Spannungsregler
- Schwarze Sitzhöhenverstellung

## 3. GASFEDER :

Sitzhöhenverstellung, drehbar, verchromt

## 4. GESTELL :

5-Stern Alu poliertes Fußkreuz, Ø 710 mm

## 5. ROLLEN :

Ø 50 mm gebremste, oder weiche gebremste Rollen, schwarz

## 6. ARMLEHNE :

Feste Armlehne aus Stahlstab Ø 12mm, verchromt (15µm), weiche Polyurethan Armauflage oder Gepolstert

## 1. RESPALDO Y ASIENTO:

Monocasco en espuma inyectado a frio con estructura de soporte en tubo de acero redondo, Ø 20 mm, tapizado

## 2. MECANISMO:

- Tilting, control de elevación de gas, ajuste de tensión posterior
- Control de elevación de gas, acabado negro

## 3. GAS:

Ajustable en altura, rotación, acabado cromado

## 4. BASE:

5 radios en aluminio, Ø 710mm, acabado pulido

## 5. RUEDAS:

Ø 50 mm, blandas o autofrenado y blandas, acabado negro

## 6. BRAZOS:

Brazos fijo en tubo de acero 12mm, acabado cromado, tapizado y poliuretano suave o tapizado

## TECHNICAL INFORMATION

### IMPERIALE

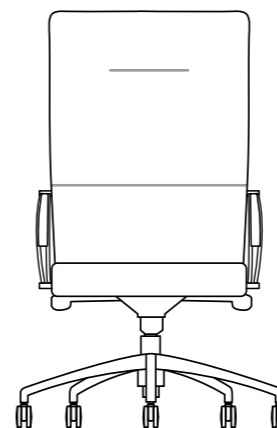

### REGALE

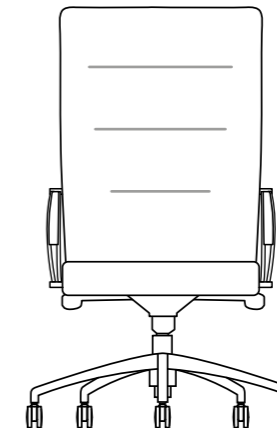

### DUCALE

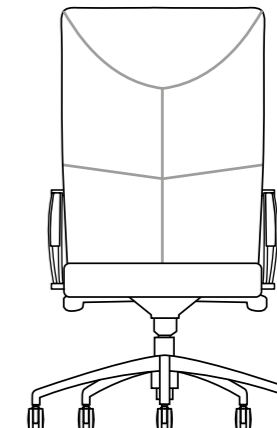

# AURELIA

SCocca IN POLIURETANO, STRUTTURA IN METALLO, INTERAMENTE TAPPEZZATA  
 POLYURETANE SHELL, METAL STRUCTURE, FULLY UPHOLSTERED  
 COQUE EN POLYURETHANE, STRUCTURE EN METAL, ENTIÈREMENT TAPISSEÉ  
 POLYURETHANSCHALE, METALLSTRUKTUR, AUSGEPOLSTERT  
 CONCHA EN POLIURETANO, ESTRUCTURA EN METAL, COMPLETAMENTE TAPIZADA

## IMPERIALE

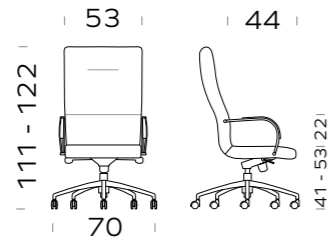
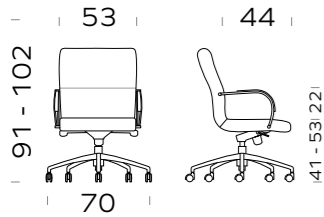

Mechanism: **Tilting BASIC**



Blocco oscillante-4 posizioni, Regolazione altezza/tensione  
 (Un-)locking device-4 positions, Height/tension adjustment  
 Système de blocage-débloqué de l'oscillation-4 positions, Réglage en hauteur/ d'intensité  
 Blockierung der Rückenlehne /Spannungsregler / Höhenverstellung-4 Positionen  
 Sistema de bloqueo-desbloqueo del respaldo-4 posiciones, Ajuste de altura/tensión

BASE BASE PIETEMENT GESTELL BASE	RUOTA/PIEDINO CASTOR/FEET ROULETTES/PATINS ROLLEN/GLEITER RUEDAS/PIES	STRUTTURA STRUCTURE STRUCTURE STRUKTUR ESTRUCTURA	SCHIENALE BACKREST DOSSIER RÜCKENLEHNE RESPALDO	CODICE CODE CODE ARTIKEL CÓDIGO	KG	TESSUTI/FINITURE UPHOLSTERIES/FINISHING REVETEMENTS STOFFGRUPPE TAPICERIAS			
						D	E	F	G
		Chromed	Medium	<b>AR0256</b>	13,90	775	799	814	952
			High	<b>AR0246</b>	14,60	797	814	843	995
		RAL 9005	Medium	<b>AR0251</b>	13,90	775	799	814	952
			High	<b>AR0241</b>	14,60	797	814	843	995
		RAL 9005	Medium	<b>AR0285</b>	13,20	713	737	752	890
			High	<b>AR0284</b>	13,90	735	752	781	933
		RAL 9005	Medium	<b>AR0306</b>	13,20	720	744	759	897
			High	<b>AR0307</b>	13,90	742	759	788	940

\* DISPONIBILE ANCHE IN  
 ALSO AVAILABLE  
 ÉGALEMENT DISPONIBLE EN  
 ERHÄLTlich AUCH IN  
 TAMBIÉN DISPONIBLE EN



RAL 9016



RAL 1012



RAL 3012



RAL 6021



RAL 7032



RAL 7046

# AURELIA

SCocca IN POLIURETANO, STRUTTURA IN METALLO, INTERAMENTE TAPPEZZATA  
 POLYURETANE SHELL, METAL STRUCTURE, FULLY UPHOLSTERED  
 COQUE EN POLYURETHANE, STRUCTURE EN METAL, ENTIÈREMENT TAPISSEÉ  
 POLYURETHANSCHALE, METALLSTRUKTUR, AUSGEPOLSTERT  
 CONCHA EN POLIURETANO, ESTRUCTURA EN METAL, COMPLETAMENTE TAPIZADA

## IMPERIALE

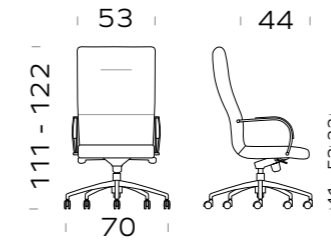
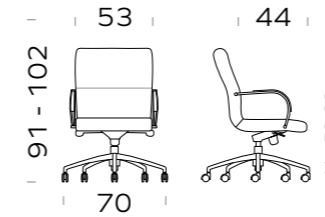

Mechanism: **Tilting ADVANCED PIVOT POINT**



Blocco oscillante-5 posizioni, Regolazione altezza/tensione  
 (Un-)locking device-5 positions, Height/tension adjustment  
 Système de blocage-débloqué de l'oscillation-5 positions, Réglage en hauteur/ d'intensité  
 Blockierung der Rückenlehne /Spannungsregler / Höhenverstellung-5 Positionen  
 Sistema de bloqueo-desbloqueo del respaldo-5 posiciones, Ajuste de altura/tensión

BASE BASE PIETEMENT GESTELL BASE	RUOTA/PIEDINO CASTOR/FEET ROULETTES/PATINS ROLLEN/GLEITER RUEDAS/PIES	STRUTTURA STRUCTURE STRUCTURE STRUKTUR ESTRUCTURA	SCHIENALE BACKREST DOSSIER RÜCKENLEHNE RESPALDO	CODICE CODE CODE ARTIKEL CÓDIGO	KG	TESSUTI/FINITURE UPHOLSTERIES/FINISHING REVETEMENTS STOFFGRUPPE TAPICERIAS			
						D	E	F	G
		Chromed	Medium	<b>AR0302</b>	14,20	835	859	874	1012
			High	<b>AR0303</b>	14,90	857	874	903	1055
		RAL 9005	Medium	<b>AR0304</b>	14,20	835	859	874	1012
			High	<b>AR0305</b>	14,90	857	874	903	1055

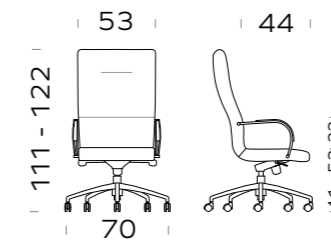
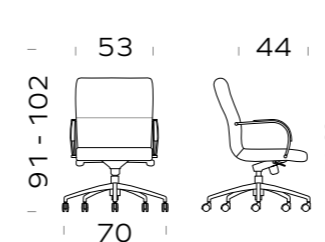

Mechanism: **SeatPlate**



Regolazione altezza  
 Height adjustment  
 Réglage en hauteur  
 Höhenverstellung  
 Ajuste de altura

BASE BASE PIETEMENT GESTELL BASE	RUOTA/PIEDINO CASTOR/FEET ROULETTES/PATINS ROLLEN/GLEITER RUEDAS/PIES	STRUTTURA STRUCTURE STRUCTURE STRUKTUR ESTRUCTURA	SCHIENALE BACKREST DOSSIER RÜCKENLEHNE RESPALDO	CODICE CODE CODE ARTIKEL CÓDIGO	KG	TESSUTI/FINITURE UPHOLSTERIES/FINISHING REVETEMENTS STOFFGRUPPE TAPICERIAS			
						D	E	F	G
		Chromed	Medium	<b>AR0186</b>	12,30	683	706	723	860
			High	<b>AR0166</b>	13,10	706	730	751	905
		RAL 9005	Medium	<b>AR0286</b>	12,30	683	706	723	860
			High	<b>AR0287</b>	13,10	706	730	751	905

\* DISPONIBILE ANCHE IN  
 ALSO AVAILABLE  
 ÉGALEMENT DISPONIBLE EN  
 ERHÄLTlich AUCH IN  
 TAMBIÉN DISPONIBLE EN

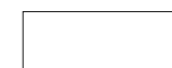

RAL 9016



RAL 1012



RAL 3012



RAL 6021



RAL 7032



RAL 7046

# AURELIA

SCocca IN POLIURETANO, STRUTTURA IN METALLO, INTERAMENTE TAPPEZZATA  
 POLYURETANE SHELL, METAL STRUCTURE, FULLY UPHOLSTERED  
 COQUE EN POLYURETHANE, STRUCTURE EN METAL, ENTIÈREMENT TAPISSEÉ  
 POLYURETHANSCHALE, METALLSTRUKTUR, AUSGEPOLSTERT  
 CONCHA EN POLIURETANO, ESTRUCTURA EN METAL, COMPLETAMENTE TAPIZADA

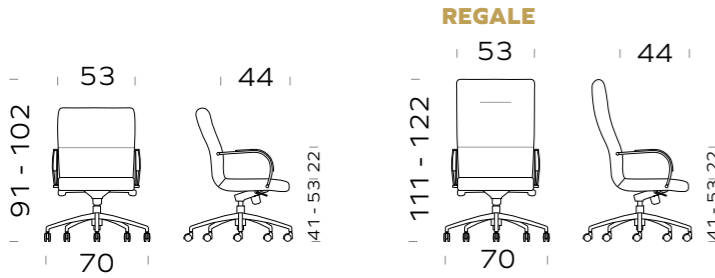

Mechanism: **Tilting BASIC**



Blocco oscillante-4 posizioni, Regolazione altezza/tensione  
 (Un-)locking device-4 positions, Height/tension adjustment  
 Système de blocage-débloccage de l'oscillation-4 positions, Réglage en hauteur/ d'intensité  
 Blockierung der Rückenlehne /Spannungsregler / Höhenverstellung-4 Positionen  
 Sistema de bloqueo-desbloqueo del respaldo-4 posiciones, Ajuste de altura/tensión

BASE BASE PIETEMENT GESTELL BASE	RUOTA/PIEDINO CASTOR/FEET ROULETTES/PATINS ROLLEN/GLEITER RUEDAS/PIES	STRUTTURA STRUCTURE STRUCTURE STRUKTUR ESTRUCTURA	SCHIENALE BACKREST DOSSIER RÜCKENLEHNE RESPALDO	CODICE CODE CODE ARTIKEL CÓDIGO	KG	TESSUTI/FINITURE UPHOLSTERIES/FINISHING REVÊTEMENTS STOFFGRUPPE TAPICERIAS			
						D	E	F	G
		Chromed	Medium	AR0276	13,90	775	799	814	952
			High	AR0266	14,60	797	823	843	995
		RAL 9005	Medium	AR0271	13,90	775	799	814	952
			High	AR0261	14,60	797	823	843	995
		RAL 9005	Medium	AR0312	13,20	713	737	752	890
			High	AR0313	13,90	735	761	781	933
		RAL 9005	Medium	AR0314	13,20	720	744	759	897
			High	AR0315	13,90	742	768	788	940

\* DISPONIBILE ANCHE IN  
 ALSO AVAILABLE  
 ÉGALEMENT DISPONIBLE EN  
 ERHÄLTlich AUCH IN  
 TAMBIÉN DISPONIBLE EN

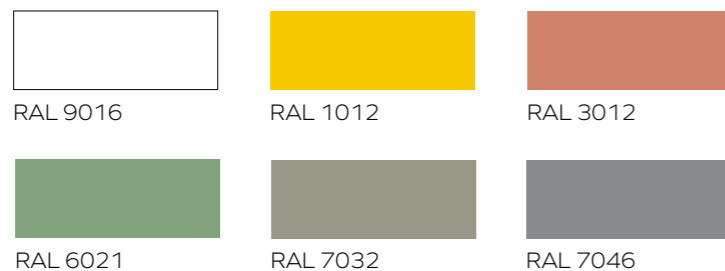

# AURELIA

SCocca IN POLIURETANO, STRUTTURA IN METALLO, INTERAMENTE TAPPEZZATA  
 POLYURETANE SHELL, METAL STRUCTURE, FULLY UPHOLSTERED  
 COQUE EN POLYURETHANE, STRUCTURE EN METAL, ENTIÈREMENT TAPISSEÉ  
 POLYURETHANSCHALE, METALLSTRUKTUR, AUSGEPOLSTERT  
 CONCHA EN POLIURETANO, ESTRUCTURA EN METAL, COMPLETAMENTE TAPIZADA

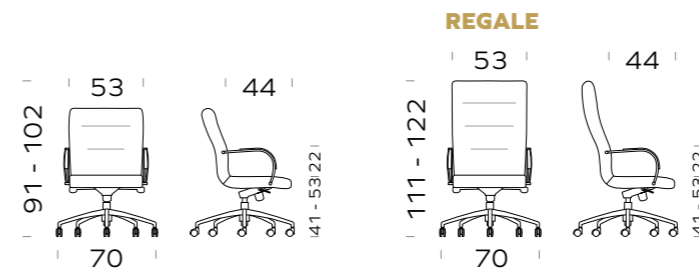

Mechanism: **Tilting ADVANCED PIVOT POINT**



Blocco oscillante-5 posizioni, Regolazione altezza/tensione  
 (Un-)locking device-5 positions, Height/tension adjustment  
 Système de blocage-débloccage de l'oscillation-5 positions, Réglage en hauteur/ d'intensité  
 Blockierung der Rückenlehne /Spannungsregler / Höhenverstellung-5 Positionen  
 Sistema de bloqueo-desbloqueo del respaldo-5 posiciones, Ajuste de altura/tensión

BASE BASE PIETEMENT GESTELL BASE	RUOTA/PIEDINO CASTOR/FEET ROULETTES/PATINS ROLLEN/GLEITER RUEDAS/PIES	STRUTTURA STRUCTURE STRUCTURE STRUKTUR ESTRUCTURA	SCHIENALE BACKREST DOSSIER RÜCKENLEHNE RESPALDO	CODICE CODE CODE ARTIKEL CÓDIGO	KG	TESSUTI/FINITURE UPHOLSTERIES/FINISHING REVÊTEMENTS STOFFGRUPPE TAPICERIAS			
						D	E	F	G
		Chromed	Medium	AR0308	14,20	835	859	874	1012
			High	AR0309	14,90	857	883	903	1055
		RAL 9005	Medium	AR0310	14,20	835	859	874	1012
			High	AR0311	14,90	857	883	903	1055

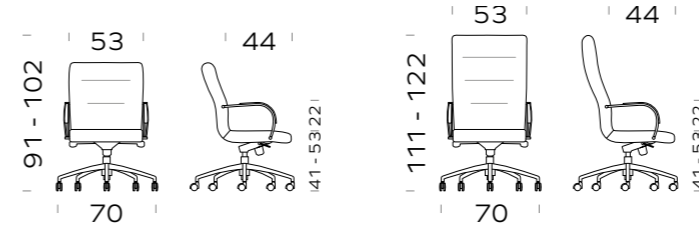

Mechanism: **SeatPlate**



Regolazione altezza  
 Height adjustment  
 Réglage en hauteur  
 Höhenverstellung  
 Ajuste de altura

BASE BASE PIETEMENT GESTELL BASE	RUOTA/PIEDINO CASTOR/FEET ROULETTES/PATINS ROLLEN/GLEITER RUEDAS/PIES	STRUTTURA STRUCTURE STRUCTURE STRUKTUR ESTRUCTURA	SCHIENALE BACKREST DOSSIER RÜCKENLEHNE RESPALDO	CODICE CODE CODE ARTIKEL CÓDIGO	KG	TESSUTI/FINITURE UPHOLSTERIES/FINISHING REVÊTEMENTS STOFFGRUPPE TAPICERIAS			
						D	E	F	G
		Chromed	Medium	AR0214	12,30	683	701	723	860
			High	AR0280	13,10	706	730	751	905
		RAL 9005	Medium	AR0288	12,30	683	701	723	860
			High	AR0289	13,10	706	730	751	905

\* DISPONIBILE ANCHE IN  
 ALSO AVAILABLE  
 ÉGALEMENT DISPONIBLE EN  
 ERHÄLTlich AUCH IN  
 TAMBIÉN DISPONIBLE EN

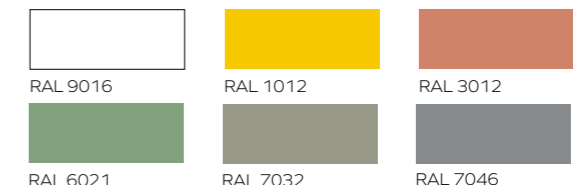

# AURELIA

SCocca IN POLIURETANO, STRUTTURA IN METALLO, INTERAMENTE TAPPEZZATA  
 POLYURETANE SHELL, METAL STRUCTURE, FULLY UPHOLSTERED  
 COQUE EN POLYURETHANE, STRUCTURE EN METAL, ENTIÈREMENT TAPISSEÉ  
 POLYURETHANSCHALE, METALLSTRUKTUR, AUSGEPOLSTERT  
 CONCHA EN POLIURETANO, ESTRUCTURA EN METAL, COMPLETAMENTE TAPIZADA

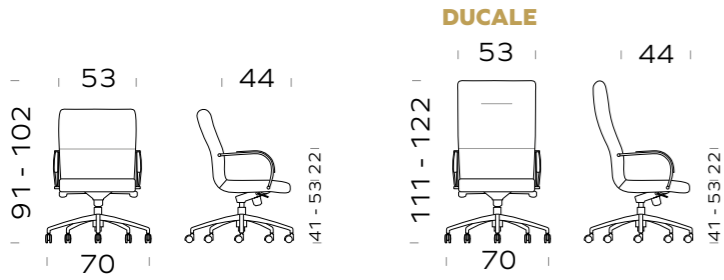

Mechanism: **Tilting BASIC**



Blocco oscillante-4 posizioni, Regolazione altezza/tensione  
 (Un-)locking device-4 positions, Height/tension adjustment  
 Système de blocage-débloqué de l'oscillation-4 positions, Réglage en hauteur/ d'intensité  
 Blockierung der Rückenlehne /Spannungsregler / Höhenverstellung-4 Positionen  
 Sistema de bloqueo-desbloqueo del respaldo-4 posiciones, Ajuste de altura/tensión

BASE BASE PIETEMENT GESTELL BASE	RUOTA/PIEDINO CASTOR/FEET ROULETTES/PATINS ROLLEN/GLEITER RUEDAS/PIES	STRUTTURA STRUCTURE STRUCTURE STRUKTUR ESTRUCTURA	SCHIENALE BACKREST DOSSIER RÜCKENLEHNE RESPALDO	CODICE CODE CODE ARTIKEL CÓDIGO	KG	TESSUTI/FINITURE UPHOLSTERIES/FINISHING REVETEMENTS STOFFGRUPPE TAPICERIAS			
						D	E	F	G
		Chromed	Medium	AR0236	13,90	763	785	801	924
			High	AR0226	14,60	785	808	823	960
		RAL 9005	Medium	AR0231	13,90	763	785	801	924
			High	AR0221	14,60	785	808	823	960
		RAL 9005	Medium	AR0320	13,20	701	723	739	862
			High	AR0321	13,90	723	746	761	898
		RAL 9005	Medium	AR0323	13,20	708	730	746	869
			High	AR0322	13,90	730	753	768	905

\* DISPONIBILE ANCHE IN  
 ALSO AVAILABLE  
 ÉGALEMENT DISPONIBLE EN  
 ERHÄLTICH AUCH IN  
 TAMBIÉN DISPONIBLE EN



# AURELIA

SCocca IN POLIURETANO, STRUTTURA IN METALLO, INTERAMENTE TAPPEZZATA  
 POLYURETANE SHELL, METAL STRUCTURE, FULLY UPHOLSTERED  
 COQUE EN POLYURETHANE, STRUCTURE EN METAL, ENTIÈREMENT TAPISSEÉ  
 POLYURETHANSCHALE, METALLSTRUKTUR, AUSGEPOLSTERT  
 CONCHA EN POLIURETANO, ESTRUCTURA EN METAL, COMPLETAMENTE TAPIZADA

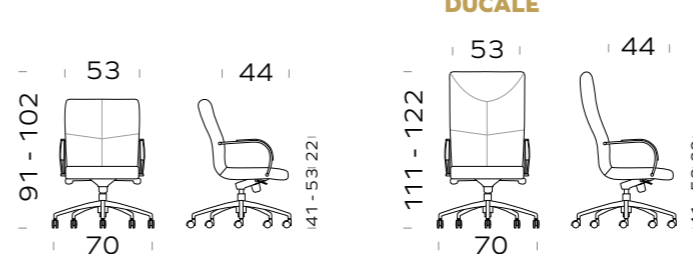

Mechanism: **Tilting ADVANCED PIVOT POINT**



Blocco oscillante-5 posizioni, Regolazione altezza/tensione  
 (Un-)locking device-5 positions, Height/tension adjustment  
 Système de blocage-débloqué de l'oscillation-5 positions, Réglage en hauteur/ d'intensité  
 Blockierung der Rückenlehne /Spannungsregler / Höhenverstellung-5 Positionen  
 Sistema de bloqueo-desbloqueo del respaldo-5 posiciones, Ajuste de altura/tensión

BASE BASE PIETEMENT GESTELL BASE	RUOTA/PIEDINO CASTOR/FEET ROULETTES/PATINS ROLLEN/GLEITER RUEDAS/PIES	STRUTTURA STRUCTURE STRUCTURE STRUKTUR ESTRUCTURA	SCHIENALE BACKREST DOSSIER RÜCKENLEHNE RESPALDO	CODICE CODE CODE ARTIKEL CÓDIGO	KG	TESSUTI/FINITURE UPHOLSTERIES/FINISHING REVETEMENTS STOFFGRUPPE TAPICERIAS			
						D	E	F	G
		Chromed	Medium	AR0316	14,20	823	845	861	984
			High	AR0317	14,90	845	868	883	1020
		RAL 9005	Medium	AR0318	14,20	823	845	861	984
			High	AR0319	14,90	845	868	883	1020

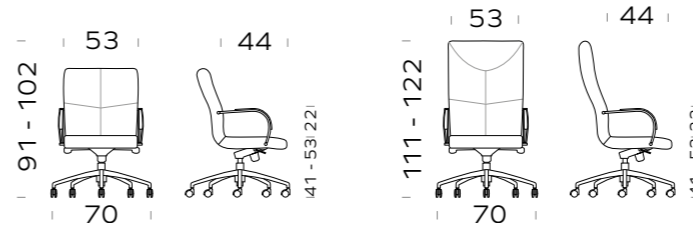

Mechanism: **SeatPlate**











Regolazione altezza  
 Height adjustment  
 Réglage en hauteur  
 Höhenverstellung  
 Ajuste de altura

BASE BASE PIETEMENT GESTELL BASE	RUOTA/PIEDINO CASTOR/FEET ROULETTES/PATINS ROLLEN/GLEITER RUEDAS/PIES	STRUTTURA STRUCTURE STRUCTURE STRUKTUR ESTRUCTURA	SCHIENALE BACKREST DOSSIER RÜCKENLEHNE RESPALDO	CODICE CODE CODE ARTIKEL CÓDIGO	KG	TESSUTI/FINITURE UPHOLSTERIES/FINISHING REVETEMENTS STOFFGRUPPE TAPICERIAS			
						D	E	F	G
		Chromed	Medium	AR0146	12,30	674	693	710	834
			High	AR0126	13,10	693	717	734	870
		RAL 9005	Medium	AR0290	12,30	674	693	710	834
			High	AR0291	13,10	693	717	734	870

\* DISPONIBILE ANCHE IN  
 ALSO AVAILABLE  
 ÉGALEMENT DISPONIBLE EN  
 ERHÄLTICH AUCH IN  
 TAMBIÉN DISPONIBLE EN



# AURELIA **OPTIONALS**

OPZIONE OPTIONALS OPTIONS OPTIONEN OPCIONES	VARIANTE VARIANT VARIANTE VARIANTE VARIANTE	CODICE CODE CODE ARTIKEL CÓDIGO	KG	PREZZO PRICE PRIX PREIS PRECIO	TESSUTI/FINITURE UPHOLSTERIES/FINISHING REVETEMENTS STOFFGRUPPE TAPICERIAS				
					D	E	F	G	H
	 Chromed	<b>XB067</b>	2,00	173					
	*  RAL 9005	<b>XB110</b>	2,00	173					
	 Chromed	<b>XB068</b>	2,00		187	187	187	187	187
	*  RAL 9005	<b>XB108</b>	2,00		187	187	187	187	187
	Small Desk Pad 50x35 cm	<b>XA020</b>	2,3					130	
	Large Desk Pad 80x50 cm	<b>XA021</b>	5,3					246	

\* DISPONIBILE ANCHE CON  
ALSO AVAIABLE WITH  
ÉGALEMENT DISPONIBLE AVEC  
ERHÄLTlich AUCH MIT  
TAMBIÉN DISPONIBLE CON



d.50 mm autofrenanti  
self-braking d.50mm  
d.50mm autofreinante  
gebremste D.50mm  
diam.50 autofreno

**SAME PRICE**

\* DISPONIBILE ANCHE IN  
ALSO AVAILABLE  
ÉGALEMENT DISPONIBLE EN  
ERHÄLTlich AUCH IN  
TAMBIÉN DISPONIBLE EN



RAL 9016



RAL 1012



RAL 3012



RAL 6021



RAL 7032



RAL 7046

 **MOVING**

# AURELIA Visitor

idea: *Pietro Lovato*



## TECHNICAL INFORMATION

### 1. SCHIENALE E SEDILE:

Monoscocca in spugna schiumata a freddo con struttura portante in tubo tondo d'acciaio, Ø 16mm, rivestita

### 2. BASE:

Base a slitta in tubo rettangolare d'acciaio, 40x20mm, finitura cromata (15µm)

### 3. PIEDINI:

Tappi antiribaltamento in poliamide, finitura nera

### 1. BACKREST AND SEAT :

Cold injected foam padding monocoque, Ø 16mm steel tube structure, upholstery

### 2. BASE:

Cantilever base, 40x20mm, rect. Steel tube, chromed finish (15µm)

### 3. FEET:

Polyamide anti overturning plugs, black finish

### 1. DOSSIER ET ASSISE:

Monocoque en mousse moulée à froids avec châssis en tube d'acier rond, Ø 16mm, tapissée

### 2. PIÈTEMENT:

Piètement luge en tube d'acier rectangulaire, 40x20mm, finition chromé (15µm)

### 3. PATINS:

Tampons anti renversement en polyamide, finition noir

### 1. RÜCKENLEHNE, SITZ :

Stahlrohrschale, Ø 16mm, ausgepölstert mit kaltgeschäumten Polyurethan und Bezug

### 2. GESTELL :

Kufengestell, 40x20mm Vierkantstahlrohr, verchromt (15µm)

### 3. GLEITER :

Schwarze Polyamid antirallgleiter

### 1. RESPALDO Y ASIENTO:

Monocasco en espuma inyectado a frio con estructura de soporte en tubo de acero redondo, Ø 16 mm, tapizado

### 2. BASE:

Base de trineo en tubo de acero rectangular, 40x20mm, acabado cromado (15µm)

### 3. PIES:

Tapones antivuelco en poliamida, acabado negro.





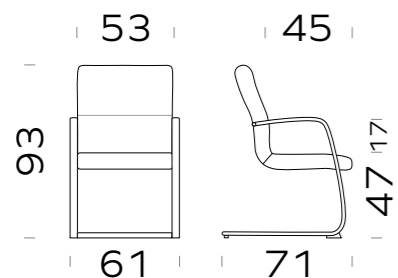

# AURELIA

SCocca IN POLIURETANO, STRUTTURA IN METALLO, INTERAMENTE TAPPEZZATA, SCHIENALE MEDIO  
 POLYURETANE SHELL, METAL STRUCTURE, FULLY UPHOLSTERED, MEDIUM BACKREST  
 COQUE EN POLYURETHANE, STRUCTURE EN METAL, ENTIÈREMENT TAPISSÉ, MOYEN DOSSIER  
 POLYURETHANSCHALE, METALLSTRUKTUR, AUSGEPOLSTERT, MITTLERE RÜCKENLEHNE  
 CONCHA EN POLIURETANO, ESTRUCTURA EN METAL, COMPLETAMENTE TAPIZADA, MEDIO RESPALDO

## IMPERIALE





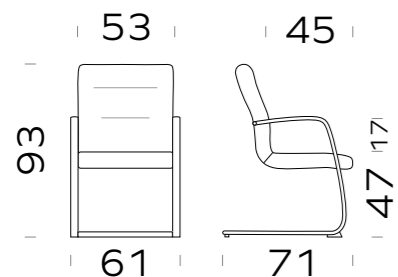

## VISITOR

BASE BASE PIETEMENT GESTELL BASE	RUOTA/PIEDINO CASTOR/FEET ROULETTES/PATINS ROLLEN/GLEITER RUEDAS/PIES	STRUTTURA STRUCTURE STRUCTURE STRUKTUR ESTRUCTURA	CODICE CODE CODE ARTIKEL CÓDIGO	KG	TESSUTI/FINITURE UPHOLSTERIES/FINISHING REVETEMENTS STOFFGRUPPE TAPICERIAS			
					D	E	F	G
 slitta con braccioli cantilever with arms luge avec accoudoirs Freischwinger Gestell mit Armlehnen patin con brazos		 Chromed	<b>AR0042</b>	14,20	856	881	897	1041
		 RAL 9005 *	<b>AR0292</b>	14,20	856	881	897	1041

## REGALE



BASE BASE PIETEMENT GESTELL BASE	RUOTA/PIEDINO CASTOR/FEET ROULETTES/PATINS ROLLEN/GLEITER RUEDAS/PIES	STRUTTURA STRUCTURE STRUCTURE STRUKTUR ESTRUCTURA	CODICE CODE CODE ARTIKEL CÓDIGO	KG	TESSUTI/FINITURE UPHOLSTERIES/FINISHING REVETEMENTS STOFFGRUPPE TAPICERIAS			
					D	E	F	G
 slitta con braccioli cantilever with arms luge avec accoudoirs Freischwinger Gestell mit Armlehnen patin con brazos		 Chromed	<b>AR0083</b>	14,20	856	881	897	1041
		 RAL 9005 *	<b>AR0293</b>	14,20	856	881	897	1041

\* DISPONIBILE ANCHE IN  
 ALSO AVAILABLE  
 ÉGALEMENT DISPONIBLE EN  
 ERHÄLTlich AUCH IN  
 TAMBIÉN DISPONIBLE EN

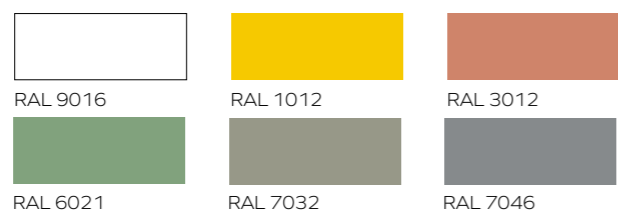



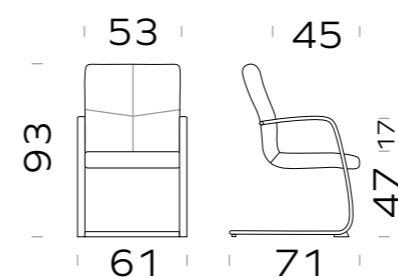

# AURELIA

SCocca IN POLIURETANO, STRUTTURA IN METALLO, INTERAMENTE TAPPEZZATA, SCHIENALE MEDIO  
 POLYURETANE SHELL, METAL STRUCTURE, FULLY UPHOLSTERED, MEDIUM BACKREST  
 COQUE EN POLYURETHANE, STRUCTURE EN METAL, ENTIÈREMENT TAPISSÉ, MOYEN DOSSIER  
 POLYURETHANSCHALE, METALLSTRUKTUR, AUSGEPOLSTERT, MITTLERE RÜCKENLEHNE  
 CONCHA EN POLIURETANO, ESTRUCTURA EN METAL, COMPLETAMENTE TAPIZADA, MEDIO RESPALDO

## DUCALE



BASE BASE PIETEMENT GESTELL BASE	RUOTA/PIEDINO CASTOR/FEET ROULETTES/PATINS ROLLEN/GLEITER RUEDAS/PIES	STRUTTURA STRUCTURE STRUCTURE STRUKTUR ESTRUCTURA	CODICE CODE CODE ARTIKEL CÓDIGO	KG	TESSUTI/FINITURE UPHOLSTERIES/FINISHING REVETEMENTS STOFFGRUPPE TAPICERIAS			
					D	E	F	G
 slitta con braccioli cantilever with arms luge avec accoudoirs Freischwinger Gestell mit Armlehnen patin con brazos		 Chromed	<b>AR0001</b>	14,20	846	868	883	1013
		 RAL 9005 *	<b>AR0294</b>	14,20	846	868	883	1013

## IMPERIALE

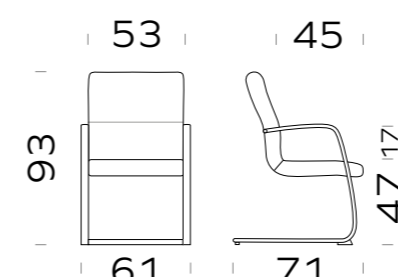

## REGALE

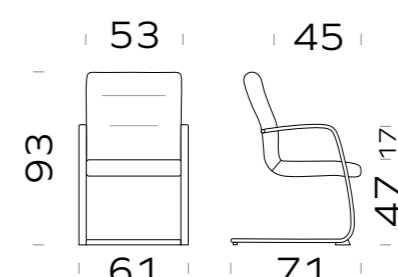

## DUCALE

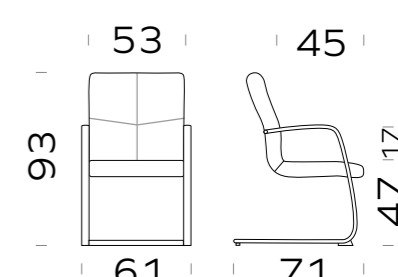

OPZIONE OPTIONALS OPTIONS OPTIONEN OPCIONES	CODICE CODE CODE ARTIKEL CÓDIGO	KG	TESSUTI/FINITURE UPHOLSTERIES/FINISHING REVETEMENTS STOFFGRUPPE TAPICERIAS				
			D	E	F	G	H
	<b>XH007</b>	0,20	38	38	38	38	38

\* DISPONIBILE ANCHE IN  
 ALSO AVAILABLE  
 ÉGALEMENT DISPONIBLE EN  
 ERHÄLTlich AUCH IN  
 TAMBIÉN DISPONIBLE EN



VIVA  
idea: *Pietro Lovato*



**1. SCHIENALE:**

Schienale in spugna schiumata a freddo con struttura portante in tubo quadro d'acciaio, 15x15mm, rivestita

**2. SEDILE:**

Sedile in spugna schiumata a freddo con struttura portante in tubo tondo d'acciaio, Ø 16mm, rivestita

**3. MECCANISMO:**

- Oscillante nero, comando elevazione a gas, regolazione tensione schienale, inclinazione 18° scocca in 5 posizioni con antishock
- Comando elevazione a gas, finitura nera

**4. GAS:**

- Regolabile in altezza, rotazione, finitura cromata
- Regolabile in altezza, rotazione, finitura cromata, molleggio

**5. BASE:**

- Base 5 razze in ferro, Ø 710mm, finitura cromata (15µm)
- Base 5 razze in alluminio, Ø 710mm, finitura lucida

**6. RUOTE:**

- Ø 65mm, gommate o autofrenanti e gommate, finitura nera.
- Ø 50mm, autofrenanti o autofrenanti e gommate, finitura cromata

**7. BRACCIOLI:**

Bracciolo fisso in piatto d'acciaio, 25x5mm, finitura cromata (15µm) imbottito e rivestito

**1. BACKREST :**

Cold injected foam padded backrest steel square tube, 15x15mm structure, upholstery

**2. SEAT:**

Cold injected foam padded seat, steel round bar Ø16mm structure, upholstery

**3. MECHANISM:**

- Black, tilting, gas lift height adj., backrest tension adj. 18° grade with 5 locking position, and antishock
- Height adjustable, Black finish

**4. GAS LIFT:**

- Height adjustable, swivel, chromed finish
- Height adjustable, swivel, chromed finish, shock absorber springs

**5. BASE:**

- Iron 5 spoke base, Ø 710 mm chromed finish (15µm)
- Polished aluminium 5 spoke base, Ø 710 mm

**6. CASTORS:**

- Ø 65mm self-braking castors, or soft self-braking. Black finish
- Ø 50 mm self-braking castors, or soft self-braking. Chrome finish

**7. ARMREST:**

Steel plate fixed armrest, 25x5mm, chromed finish (15µm), padded and upholstered

**1. DOSSIER:**

Dossier en mousse moulée à froids avec châssis en tube d'acier carré, 15x15mm, tapissée

**2. ASSISE:**

Assise en mousse moulée à froids avec châssis en tube d'acier rond, Ø 16mm, tapissée

**3. MECANISME:**

- Basculant noir, réglage en hauteur, réglage de tension, inclinaison coque 18° en 5 positions avec système antichoc
- Réglable en hauteur, finition noir

**4. VERIN A GAZ:**

- Réglable en hauteur, pivotant, finition chromé
- Réglable en hauteur, pivotant, finition chromé, amortisseur

**5. PIÈTEMENT:**

- Piètement 5 branches alu poli, Ø 710mm
- Piètement 5 branches en métal, Ø 710mm, finition chromé (15µm)

**6. ROULETTES:**

- Roulettes Ø 65mm, gommées ou autofrenantes et gommées, finition noir
- Roulettes Ø 50mm, autofrenantes ou autofrenantes et gommées, finition chromé

**7. ACCOUDOIR:**

Accoudoir fixe plat en acier, 25x5mm, finition chromé (15µm) rembourré et tapissé

**1. RÜCKENLEHNE :**

Kaltgeschäumten Polyurethan, 15x15mm Vierkantstahlrohr Schale

**2. SITZ :**

Ø 16mm Stahlstab schale, ausgepolstert mit kaltgeschäumten Polyurethan, mit Bezug

**3. MECHANIK :**

- schwarze Wippmechanik, Gaslift Höhenverstellung, Rückenlehne mit Spannungsregler, 18°Schaleneigung mit 5-stufige Einstellung
- schwarze
- Sitzhöhenverstellung

**4. GASFEDER :**

- Sitzhöhenverstellung, drehbar, verchromt
- Sitzhöhenverstellung, drehbar, verchromt, mit Stoßdämpfende Feder

**5. GESTELL :**

- 5-Stern Alu poliertes Fußkreuz, Ø 710 mm
- 5-Stern Eisen Fußkreuz, Ø 710mm verchromt (15µm)

**6. ROLLEN :**

- Ø 65 mm gebremste, oder weiche gebremste Rollen, schwarze
- Ø 50 mm gebremste, oder weiche gebremste Rollen, verchromt

**7. ARMLEHNEN**

Feste Armlehne aus Flachstahl, 25x5 mm, verchromt (15µm) ausgepolstert mit Bezug

**1. RESPALDO:**

Respaldo de espuma inyectada a frio con estructura de soporte en tubo de acero cuadrado, 15x15mm, tapizado

**2. ASIENTO:**

Asiento de espuma inyectada a frio con estructura de soporte en tubo de acero redondo, Ø 16 mm, tapizado

**3. MECANISMO:**

- Tilting, control de elevación de gas, ajuste de tensión posterior, cuerpo de inclinación de 18° en 5 posiciones con antishock
- Control de elevación de gas, acabado negro

**4. GAS:**

- Ajustable en altura, rotación, acabado cromado
- Ajustable en altura, rotación, acabado cromado, resortes

**5. BASE:**

- Base de 5 estrellas en hierro, Ø 710 mm, acabado cromado (15µm)
- Base de 5 estrellas en aluminio, Ø 710 mm, acabado pulido (15µm)

**6. RUEDAS:**

- Ø 65mm, blandas o autofrenado y blandas, acabado negro
- Ruedas de Ø 50 mm, autofrenantes o autofrenantes y blandas, cromado

**7. BRAZOS:**

Brazo fijo en chapa de acero, 25x5 mm, acabado cromado (15µm) tapizado



# VIVA



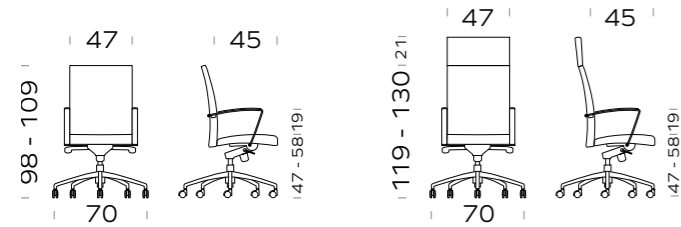





IMBOTTITA, SCHIENALE MEDIO  
UPHOLSTERED, MEDIUM BACKREST  
REMOURRÉ, MOYEN DOSSIER  
GEPOLSTERT, MITTLERE RÜCKENLEHNE  
TAPIZADA, MEDIO RESPLADO



Mechanism: **SeatPlate** ↑



Regolazione altezza  
Height adjustment  
Réglage en hauteur  
Höhenverstellung  
Ajuste de altura

BASE BASE PIÈTEMENT GESTELL BASE	RUOTA/PIEDINO CASTOR/FEET ROULETTES/PATINS ROLLEN/GLEITER RUEDAS/PIES	STRUTTURA STRUCTURE STRUCTURE STRUKTUR ESTRUCTURA	CODICE CODE CODE ARTIKEL CÓDIGO	KG	TESSUTI/FINITURE UPHOLSTERIES/FINISHING REVÈTEMENTS STOFFGRUPPE TAPICERÍAS		
					F	G	H
		 Chromed	<b>VI0011</b>	16,60	862	1073	1232
		 RAL 9005	<b>VI0044</b>	16,60	862	1073	1232
		 Chromed	<b>VI0015</b>	18,20	1021	1232	1449
		 RAL 9005	<b>VI0045</b>	18,20	964	1175	1392

\* DISPONIBILE ANCHE IN  
ALSO AVAILABLE  
ÉGALEMENT DISPONIBLE EN  
ERHÄLTlich AUCH IN  
TAMBIÉN DISPONIBLE EN



RAL 9016



RAL 1012



RAL 3012



RAL 6021



RAL 7032



RAL 7046

# VIVA



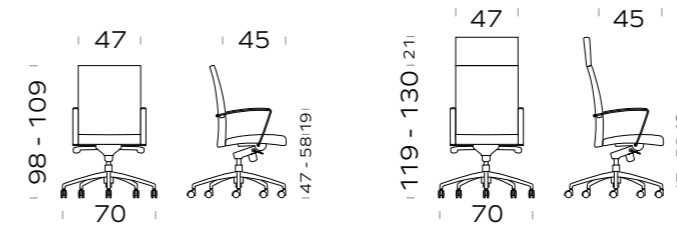









IMBOTTITA, SCHIENALE MEDIO  
UPHOLSTERED, MEDIUM BACKREST  
REMOURRÉ, MOYEN DOSSIER  
GEPOLSTERT, MITTLERE RÜCKENLEHNE  
TAPIZADA, MEDIO RESPLADO



Mechanism: **Tilting  
BASIC**



Blocco oscillante-4 posizioni, Regolazione altezza/tensione  
(Un-)locking device-4 positions, Height/tension adjustment  
Système de blocage-débloccage de l'oscillation-4 positions, Réglage en hauteur/ d'intensité  
Blockierung der Rückenlehne / Spannungsregler / Höhenverstellung-4 Positionen  
Sistema de bloqueo-desbloqueo del respaldo-4 posiciones, Ajuste de altura/tensión

BASE BASE PIÈTEMENT GESTELL BASE	RUOTA/PIEDINO CASTOR/FEET ROULETTES/PATINS ROLLEN/GLEITER RUEDAS/PIES	STRUTTURA STRUCTURE STRUCTURE STRUKTUR ESTRUCTURA	CODICE CODE CODE ARTIKEL CÓDIGO	KG	TESSUTI/FINITURE UPHOLSTERIES/FINISHING REVÈTEMENTS STOFFGRUPPE TAPICERÍAS		
					F	G	H
		 Chromed	<b>VI0049</b>	19,80	933	1148	1306
		 RAL 9005	<b>VI0050</b>	19,80	933	1148	1306
		 Chromed	<b>VI0051</b>	21,30	1092	1306	1466
		 RAL 9005	<b>VI0052</b>	21,30	1035	1249	1409
		 RAL 9005	<b>VI0053</b>	19,10	871	1086	1244
		 RAL 9005	<b>VI0054</b>	19,10	878	1093	1251

\* DISPONIBILE ANCHE IN  
ALSO AVAILABLE  
ÉGALEMENT DISPONIBLE EN  
ERHÄLTlich AUCH IN  
TAMBIÉN DISPONIBLE EN



RAL 9016



RAL 1012



RAL 3012



RAL 6021



RAL 7032



RAL 7046

# VIVA



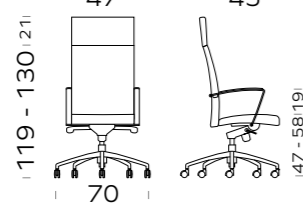
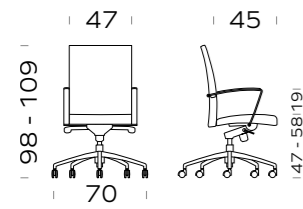





IMBOTTITA, SCHIENALE MEDIO  
UPHOLSTERED, MEDIUM BACKREST  
REMOURRÉ, MOYEN DOSSIER  
GEPOLSTERT, MITTLERE RÜCKENLEHNE  
TAPIZADA, MEDIO RESPLADO



Mechanism: **Tilting**  
**ADVANCED PIVOT POINT**



Blocco oscillante-5 posizioni, Regolazione altezza/tensione  
(Un-)locking device-5 positions, Height/tension adjustment  
Système de blocage-débloqué de l'oscillation-5 positions, Réglage en hauteur/ d'intensité  
Blockierung der Rückenlehne /Spannungsregler / Höhenverstellung-5 Positionen  
Sistema de bloqueo-desbloqueo del respaldo-5 posiciones, Ajuste de altura/tensión

BASE BASE PIETEMENT GESTELL BASE	RUOTA/PIEDINO CASTOR/FEET ROULETTES/PATINS ROLLEN/GLEITER RUEDAS/PIES	STRUTTURA STRUCTURE STRUCTURE STRUKTUR ESTRUCTURA	CODICE CODE CODE ARTIKEL CÓDIGO	KG	TESSUTI/FINITURE UPHOLSTERIES/FINISHING REVETEMENTS STOFFGRUPPE TAPICERÍAS		
					F	G	H
 5 razze in alluminio 5-spoke aluminium 5 branches alu 5 - Stern Alu Fußkreuz estrella en aluminio	 * d.65 gommate soft d.65 mm d.65mm gommées weiche D.65 mm ruedas goma diam.65	 Chromed	<b>VI0002</b>	20,10	993	1208	1366
		 * RAL 9005	<b>VI0047</b>	20,10	993	1208	1366
 5 razze in ferro 5-spoke iron 5 branches en métal 5-Stern es Eisen Fußkreuz estrella en metal	 * d.50mm autofrenanti gommate soft self-braking d.50mm d.50 mm gommées autofrein. weiche gebremste D.50 mm ruedas goma diam.50 autofreno	 Chromed	<b>VI0006</b>	21,60	1152	1366	1526
		 * RAL 9005	<b>VI0048</b>	21,60	1095	1309	1469

\* DISPONIBILE ANCHE IN  
ALSO AVAILABLE  
ÉGALEMENT DISPONIBLE EN  
ERHÄLTlich AUCH IN  
TAMBIÉN DISPONIBLE EN



RAL 9016



RAL 1012



RAL 3012



RAL 6021













RAL 7032

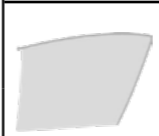

RAL 7046

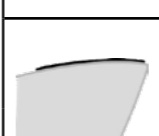
# VIVA

## OPTIONALS

OPZIONE OPTIONALS OPTIONS OPCIONEN	VARIANTE VARIANT VARIANTE VARIANTE	CODICE CODE CODE ARTIKEL CÓDIGO	KG	PREZZO PRICE PREIS PRIX PRECIO	TESSUTI/FINITURE UPHOLSTERIES/FINISHING REVETEMENTS STOFFGRUPPE TAPICERÍAS		
					F	G	H
	Chromed	<b>XB013</b>	2,40	153			
	* 	<b>XB111</b>	2,40	153			
	Chromed	<b>XB016</b>	2,50		197	197	197
	* 	<b>XB103</b>	2,50		197	197	197
	Chromed	<b>XB014</b>	2,70		387	483	497
	* 	<b>XB112</b>	2,70		387	483	497
	Chromed	<b>XB015</b>	2,80		432	528	544
	* 	<b>XB113</b>	2,80		432	528	544
	Poggiatesta Headrest Appui-tête Kopfstütze Reposacabezas	<b>XT006</b>	0,80		117	148	178
	Small Desk Pad 50x35 cm	<b>XA020</b>	2,30			130	
	Large Desk Pad 80x50 cm	<b>XA021</b>	5,30			246	

\* DISPONIBILE ANCHE CON  
ALSO AVAILABLE WITH  
ÉGALEMENT DISPONIBLE AVEC  
ERHÄLTlich AUCH MIT  
TAMBIÉN DISPONIBLE CON

d.65 mm gommate forate  
self-braking d.65 mm perforated  
d.65 mm autofreinante perforé  
gebremste Rollen Design D.65 mm  
diam.65 autofreno perforado

**+100€**

\* DISPONIBILE ANCHE IN  
ALSO AVAILABLE  
ÉGALEMENT DISPONIBLE EN  
ERHÄLTlich AUCH IN  
TAMBIÉN DISPONIBLE EN

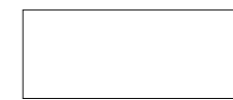

RAL 9016



RAL 1012



RAL 3012



RAL 6021



RAL 7032



RAL 7046

VIVA Visitor  
 idea: *Pietro Lovato*



## TECHNICAL INFORMATION

**1. SCHIENALE:**

Schienale in spugna schiumata a freddo con struttura portante in tubo quadro d'acciaio, 15x15mm, rivestita

**2. SEDILE:**

Sedile in multistrato di legno con spugna schiumata a freddo, rivestita

**3. BASE:**

Base a slitta in tubo rettangolare d'acciaio, 30x15mm, finitura cromata (15µm) con braccioli

**4. PIEDINI:**

Tappi antiribaltamento in poliamide, finitura cromata (15µm)

**1. BACKREST :**

Cold injected foam padded backrest steel square tube, 15x15mm structure, upholstery

**2. SEAT:**

Plywood seat, cold injected foam padded, upholstery

**3. BASE:**

Cantilever base, 30x15mm, rect. Steel tube, chromed finish (15µm) with arms

**4. FEET:**

Polyamide anti overturning plugs, chromed finish (15µm)

**1. DOSSIER:**

Dossier en mousse moulée à froids avec châssis en tube d'acier carré, 15x15mm, tapissé

**2. ASSISE:**

Assise en multiplie de bois, rembourré de mousse moulé à froids, tapissée

**3. PIÈTEMENT:**

Piètement luge en tube d'acier rectangulaire, 30x15mm, finition chromé (15µm) avec accoudoir

**4. PATINS:**

Tampons anti renversement en polyamide, finition chromé (15µm)

**1. RÜCKENLEHNE :**

Kaltgeschäumten Polyurethan. 15x15mm Vierkantstahlrohr Schale

**2. SITZ:**

Holzstiz, ausgepolstert mit Kaltgeschäumten Polyurethan

**3. GESTELL :**

Kufengestell, 30x15mm Vierkantstahlrohr, verchromt (15µm) mit Armlehnen

**5. GLEITER :**

Anti Unkippleiter aus Polyamid, verchromt (15µm)

**1. RESPALDO:**

Respaldo de espuma inyectado a frío con estructura de soporte en tubo de acero cuadrado, 15x15mm, tapizado

**2. ASIENTO:**

Asiento en madera multicapa con espuma inyectado a frío, tapizado

**3. BASE:**

Base de trineo en tubo de acero rectangular, 30x15 mm, acabado cromado (15µm) y brazos

**4. PIES:**

Tapas antivuelco de poliamida, acabado cromado (15µm)





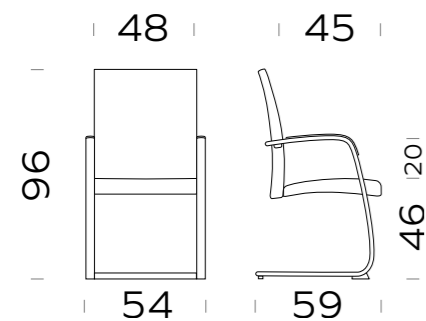

# VIVA

IMBOTTITA, SCHIENALE MEDIO  
 UPHOLSTERED, MEDIUM BACKREST  
 REMBOURRÉ, MOYEN DOSSIER  
 GEPOLSTERT, MITTLERE RÜCKENLEHNE  
 TAPIZADA, MEDIO RESPLADO



## VISITOR

BASE BASE PIETEMET GESTELL BASE	RUOTA/PIEDINO CASTOR/FEET ROULETTES/PATINS ROLLEN/GLEITER RUEDAS/PIES	STRUTTURA STRUCTURE STRUCTURE STRUKTUR ESTRUCTURA	CODICE CODE CODE ARTIKEL CÓDIGO	KG	TESSUTI/FINITURE UPHOLSTERIES/FINISHING REVETEMENTS STOFFGRUPPE TAPICERÍAS		
					F	G	H
 slitta con braccioli cantilever with arms luge avec accoudoirs Freischwinger Gestell mit Armlehnen patin con brazos	 feltrini felts feutres Filzgleiter fieltro	 Chromed	<b>VI0001</b>	20,60	961	1090	1249
		 RAL 9005 *	<b>VI0046</b>	20,60	961	1090	1249

OPZIONE OPTIONALS OPTIONS OPTIONEN OPCIONES	CODICE CODE CODE ARTIKEL CÓDIGO	KG	TESSUTI/FINITURE UPHOLSTERIES/FINISHING REVETEMENTS STOFFGRUPPE TAPICERÍAS		
			F	G	H
	XH005	0,20	33	33	33

\* DISPONIBILE ANCHE IN  
 ALSO AVAILABLE  
 ÉGALEMENT DISPONIBLE EN  
 ERHÄTLICH AUCH IN  
 TAMBIÉN DISPONIBLE EN



RAL 9016



RAL 1012



RAL 3012



RAL 6021



RAL 7032



RAL 7046

 MOVING

	ALIA C	ALIA TOP	ALIA K	ALIA LOUNGE	ARTURO	ATTIVA	AURELIA	BOHEME	CARDINALE	CARMEN	CRONO	CRONO 24	CUBIX	DAFNE	DAMA	DAMA R	DRESSCHAIR	DRESSCHAIR R	ECOCHAIR	ELETTA	FLEXA	FORMA	GIADA	GIUNONE	HOOP	IRIS	ISY	MOVING73 TASK	MOVING73 TASK STOOL	OTAVO Q	OTAVO R	PILATUS	R&G	SLIM	TOSCA	VIVA	ZIP				
D TARGET																																									
D EXPO																																									
D KING																																									
D RADIO																																									
D SILVIA																																									
E ROCCIA																																									
E ONE																																									
E CONVERT																																									
E DEMETRA																																									
E JEWEL																																									
F MINI MELANGE																																									
F PLATINUM																																									
F XTREME																																									
G CYCLE																																									
G LEATHER																																									
G LANEEL MELANGE																																									
H COLUMBIA																																									
L LINE																																									
M RETE ATTIVA																																									
M SPIDER																																									
N MICRO																																									
N TARGET																																									



Dal 1980 MOVING progetta e realizza sedie ergonomiche di alta qualità nel suo stabilimento di Trissino, Vicenza. La tradizione artigianale e l'approccio innovativo caratterizzano ogni prodotto che l'azienda propone per l'ufficio, la casa e gli spazi comuni, perchè il benessere delle persone incontra la funzionalità e l'estetica.

*Since 1980 MOVING has designed and manufactured high quality seats at their facilities in Trissino, in the Northeast Italy. Traditional craftsmanship and an innovation-driven approach characterise the brand's products, a wide range of solutions for office spaces, home and public spaces, so that wellbeing meets functionality and aesthetics.*

*Depuis 1980, MOVING conçoit et fabrique des sièges de haute qualité dans l'usine de Trissino, dans le nord-est de l'Italie. L'artisanat traditionnel et une approche axée sur l'innovation caractérisent les produits de la marque, comprenant une large gamme de solutions pour les espaces de bureau, la maison et les espaces publics, afin que le bien-être rencontre la fonctionnalité et l'esthétique.*

*Seit 1980 entwickelt und produziert Moving in seinem Werk in Trissino, Vicenza, hochwertige, ergonomische Stühle. Die handwerkliche Tradition und der innovative Ansatz, kennzeichnen jedes Produkt das das Unternehmen für Büro, Wohnbereich und Gemeinschaftsräume anbietet, damit das Wohlbefinden des Benutzers Funktionalität und Ästhetik trifft.*

*Desde 1980, Moving diseña y produce sillas ergonómicas de alta calidad en su planta de Trissino, Vicenza. La tradición artesanal y el enfoque innovador caracterizan todos los productos que la empresa ofrece para la oficina, el hogar y otros entornos donde el bienestar de las personas se encuentra con la funcionalidad y la estética.*

[movingchairs.it](http://movingchairs.it)

MOVING srl  
Via dell'Artigianato 1  
Trissino (VI) Italy  
T +39 0445 490777  
[italia@moving.vi.it](mailto:italia@moving.vi.it)  
[export@moving.vi.it](mailto:export@moving.vi.it)

[movingchairs.it](https://movingchairs.it)